



Science in School

The European journal for science teachers

Planetary energy budgets

Understanding Earth's
climate system can teach
us about other planets.

INSPIRE
Space for all
the sciences

TEACH
Experimenting with
storytelling

INSPIRE
The mathematician
who became a
biologist



PLANETARY ENERGY BUDGETS 12

Understanding Earth's climate system can teach us about other planets.



SPACE FOR ALL THE SCIENCES 23

Teachers from around Europe converged at ESA ESTEC to learn how to use space as a context for broader teaching.



EXPERIMENTING WITH STORYTELLING 41

Folktales can be a great way to introduce hands-on science into the primary-school classroom.

UNDERSTAND

- 4 **News from the EIROs:**
Space, student visits and new science
- 8 Learning from laughter
- 12 Planetary energy budgets
- 16 A safari in your mouth's microbial jungle
- 19 How neuroscience is helping us to understand attention and memory

INSPIRE

- 23 **Event report:** Space for all the sciences
- 26 **Scientist profile:** The mathematician who became a biologist
- 29 **Teacher profile:** Teacher on the high seas

TEACH

- 32 Microplastics: small but deadly
- 36 High flyers: thinking like an engineer
- 41 Experimenting with storytelling
- 45 Doing is understanding: science fun in India

THE MATHEMATICIAN 26 WHO BECAME A BIOLOGIST

Theodore Alexandrov is taking what he learned from working on the economy and applying it to the chemicals on our skin



EDITORIAL



Isabelle Kling
Editor of
Science in School

Ahead of the traditional New Year resolutions, *Science in School* has changed its look. The journal is more modern, easier to navigate and, above all, consistent with the new website that was launched in March. We hope the new design helps you to use and enjoy our content better. If you haven't already given us your feedback on our redesign, you can still do so via our online survey: <https://www.surveymonkey.com/r/7WBM8F6>

Science in School is also one step ahead of the upcoming festive season, with some handy tips on how to introduce science into the stories you tell to the youngest members of your family (p 41), and some physiological and sociological reasons why you should try to laugh together (p 8).

Hopefully the end of the year will be full of happy gatherings, with lots of hugs and kisses. Beyond lifting your mood, kissing also affects the bacterial community in your mouth (p 16), and indeed your whole body, as some recent research describes (p 26).

After the party season, it's back to reality and the need to tidy up the house, ideally while also taking care of our bigger home: Earth. As one of our regular readers found out during a memorable trip to the Arctic (p 29), many products we use daily contain microplastics that can have serious consequences for our flora and fauna (p 32). But evaluating the impact necessitates taking a step back and looking at the broader picture of what we really know about our planet (p 12). Perhaps you'll find time to watch the starry sky, dreaming about distant celestial bodies (p 23).

The *Science in School* team wishes you all a very happy New Year, with lots of good moments that trigger your brain sufficiently for you to remember them in years to come (p 19)!

Isabelle Kling

Interested in submitting
your own article? See:
www.scienceinschool.org/submit-article

Space, student visits and new science

The Globe of Science and Innovation at CERN



CERN S'Cool LAB opens its doors

The first S'Cool LAB workshops of this academic year have now begun, giving students the opportunity to get hands-on with experiments at CERN the European Organization for Nuclear Research. The one-day programme offers school students aged 16 to 19 an introductory talk and two visits to CERN's research facilities in the morning, and a workshop with hands-on experiments in the afternoon. To make the most of their time, students also prepare for their visit using an e-learning platform.

During the event, students are guided by scientists and engineers at CERN. The students work in small groups on two to three different experiments, each of which lasts about 1–1.5 hours. The exact programme of the workshop depends on the size of the group and their level of preparation, among other factors, and can be discussed between their teacher and the S'Cool LAB team.

Applications for the next round of workshops will be announced soon, so keep an eye on the S'Cool LAB newsletter at <http://scool.web.cern.ch/newsletter/scool-lab-newsletter> or subscribe to their e-mail updates online.

Based in Geneva, Switzerland, CERN is the world's largest particle physics laboratory. To learn more, see: www.cern.ch

For a list of CERN-related articles in *Science in School*, see: www.scienceinschool.org/cern

EMBL Twenty years of welcoming international summer students



This summer, the European Molecular Biology Laboratory (EMBL) again welcomed students taking part in the International Summer Science School Heidelberg (ISH). Now in its 20th year, ISH brought together talented students from four continents to gain exclusive insights into a variety of research areas. During their research internships, the students from Heidelberg's sister cities Cambridge (UK), Kumamoto (Japan), Montpellier (France), Rehovot (Israel) and Simferopol (Crimean peninsula) – as well as students from the USA and Australia – received individual practical training, heard scientific lectures and explored the Heidelberg area.

The European Learning Laboratory for the Life Sciences (ELLS) team at EMBL immensely enjoyed interacting with the students during the introductory workshop for all participants, in which students analysed fluorescent proteins – experimentally in the training labs and with bioinformatics tools in the computer lab. Two students then stayed on in the EMBL chemical biology core facility for three-week internships.

To learn more about ISH and how your students can apply, visit: www.ish-heidelberg.de

EMBL is Europe's leading laboratory for basic research in molecular biology, with its headquarters in Heidelberg, Germany. To learn more, see: www.embl.org

For a list of EMBL-related articles in *Science in School*, see: www.scienceinschool.org/embl

The 20th International Summer Science School Heidelberg 2015 at EMBL

Image courtesy of Maximilien Brice/CERN

Image courtesy of EMBL



Science in School is published by EIROforum, a collaboration between eight of Europe's largest intergovernmental scientific research organisations (EIROs). This article reviews some of the latest news from EIROs.

ESA A space-filled Christmas lecture



Image courtesy of Paul Wilkinson



Kevin Fong, 2015 Christmas lecturer

An annual tradition for many children and their parents in the UK, the Royal Institution's Christmas lectures are broadcast during the festive period and explore a different theme each year. The plans for this year's series by Kevin Fong, an expert in space medicine, will hopefully include a live video chat with the European Space Agency (ESA)'s astronaut Tim Peake on the International Space Station (ISS). The Christmas lectures began in 1825 when Michael Faraday organised the first series, on natural philosophy. Faraday established the lectures to bring science to a young audience through some of the best minds of the times, and they have taken place every year since, save for a break between 1939 and 1942. Dr Fong is a British medical doctor who also has a degree in astronautics and space engineering, and he has helped develop medical procedures for use in space. He will deliver three lectures on 'How to survive in space' and hopes to link up with Tim Peake, who is set to arrive at the ISS for the start of his mission, *Principia*, days before the lectures begin.

Find out more about the Christmas lectures, past, present and future, and how to watch them, at: <http://rigb.org/christmas-lectures>

Read more about Tim Peake and his mission at <http://timpeake.esa.int/> or follow him on Twitter at @astro_timpeake

ESA is Europe's gateway to space, with its headquarters in Paris, France. For more information, see: www.esa.int

For a list of ESA-related articles in *Science in School*, see: www.scienceinschool.org/esa

ESO ESO calendar 2016



If you don't yet have a 2016 calendar for your classroom wall, the ESO calendar is now available to order online. The calendar's cover features a spectacular picture of the European Southern Observatory (ESO)'s Very Large Telescope observing the region around the supermassive black hole at the Milky Way's centre. The calendar itself is packed with images of the cosmos as well as photographs of ESO telescopes in the rugged landscapes of northern Chile.



The 2016 calendar

To buy the calendar, visit the shop at www.eso.org/public/shop/product/calendar_2016/

Individual pages of the ESO calendar 2016 can be viewed at: www.eso.org/public/products/calendars/?search=cal2016

ESO is the world's most productive ground-based astronomical observatory, with its headquarters in Garching, near Munich in Germany, and its telescopes in Chile. For more information, see: www.eso.org

For a list of ESO-related articles in *Science in School*, see: www.scienceinschool.org/eso



EIROforum combines the resources, facilities and expertise of its member organisations to support European science in reaching its full potential. To learn more, see: www.eiroforum.org

For a list of *EIROforum*-related articles in *Science in School*, see: www.scienceinschool.org/eiroforum

To browse the other *EIRO* news articles, see: www.scienceinschool.org/eironews

ESRF Record high pressure squeezes secrets out of osmium



The metal osmium is one of the most exceptional chemical elements, with the highest known density of all elements at ambient pressure. Researchers at the European Synchrotron Radiation Facility (ESRF) have now investigated the behaviour of this metal at pressures of up to 770 Gigapascals, the highest static pressure ever achieved in a lab. Surprisingly, osmium does not change its crystal structure even at the highest pressures, but the core electrons of the atoms come so close to each other that they can interact – contrary to what is usually taught in chemistry. This fundamental result, published in the journal *Nature*, has important implications for understanding physics and chemistry of highly compressed matter, for the design of materials to be used at extreme conditions, and for modelling the interiors of giant planets and stars.



Cluster of osmium crystals grown by chemical vapour transport

Image courtesy of www.periodictable.ru, CC BY 3.0

For the full story, read the ESRF news article. See: www.esrf.eu/home/news/general/content-news/general/osmium-at-highest-pressure.html

Or read the research paper:

Dubrovinski L et al (2015) The most incompressible metal osmium at static pressures above 750 gigapascals. *Nature* **525**: 226–229. doi: 10.1038/nature14681

Situated in Grenoble, France, ESRF operates the most powerful synchrotron radiation source in Europe. To learn more, see: www.esrf.eu

For a list of ESRF-related articles in *Science in School*, see: www.scienceinschool.org/esrf

EUROfusion Runaway electrons? Not so fast



EUROfusion

Imagine the chaos in a room full of toys and energetic toddlers – there would be a lot of running around and bumping into each other. Something similar happens in a fusion experiment. When gas is heated to about 100 million degrees Celsius, the negatively charged electrons are freed from their associated nuclei, leaving them behind as positively charged ions. This mixture of hot electrons and positive ions, known as plasma, moves in random directions and its constituents collide with each other.

These collisions are exactly what scientists need for a successful fusion experiment. When two positive ions collide, they can fuse to form heavier nuclei, releasing energy. But what happens to the electrons? Usually they just move around harmlessly and collide with each other and other particles, but some become what are known as runaway

electrons, moving faster and faster, almost reaching the speed of light. If these fast-moving runaway electrons collide with the walls of the fusion experiment vessel, they can damage the vessel – something that scientists want to avoid.

To be ready to deal with these runaway electrons, scientists deliberately created runaway electrons in the medium-sized reactor at the Max Planck Institute for Plasma Physics in Garching, Germany. They triggered the runaway electrons and then prevented them from damaging the vessel wall by flooding their paths with noble gases such as argon and neon. Instead of colliding with the vessel wall, the electrons were slowed down. Now if scientists encounter electrons that run away, they know how to slow them down and prevent damage to a fusion vessel.

To learn more, read the story in EUROfusion's August issue of *Fusion in Europe*: www.euro-fusion.org/?p=56546

To read more about how a tokamak reactor works, see:

Rüth C (2012) Harnessing the power of the Sun: fusion reactors. *Science in School* **22**: 42-48. www.scienceinschool.org/2012/issue22/fusion

Interested in getting a tour of the facilities at the Max Planck Institute for Plasma Physics in Garching? Check out the details at: www.ipp.mpg.de/visitors

EUROfusion comprises 28 European member states as well as Switzerland and manages fusion research activities on behalf of Euratom. The aim is to realise fusion electricity by 2050. See: www.euro-fusion.org

For a list of EUROfusion articles in *Science in School*, see www.scienceinschool.org/EUROfusion



A runaway electron

Image courtesy of EUROfusion

European XFEL

A high-powered laser for making other-worldly conditions



Image courtesy of STFC / Central Laser Facility

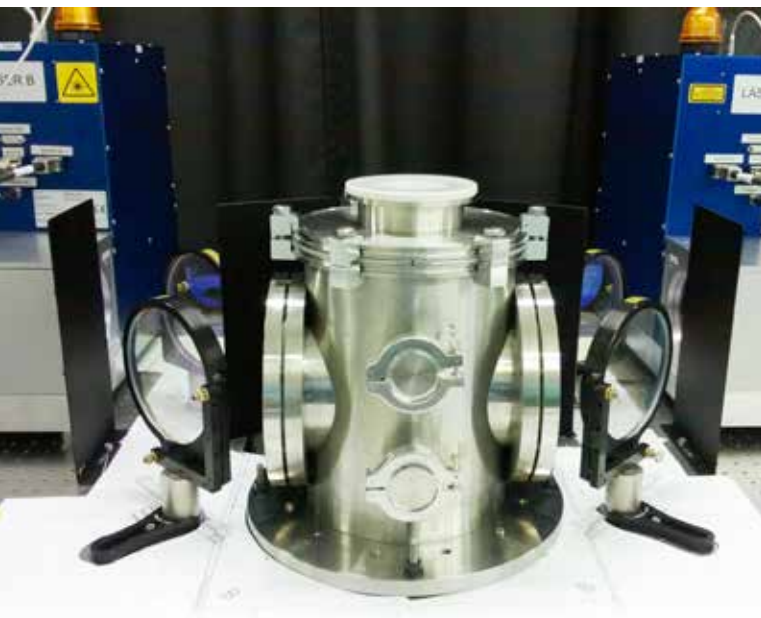

The amplifier head of the Dipole laser

The European X-ray Free Electron Laser (European XFEL) will be able to generate ultrabright X-rays that last only quadrillionths of a second, but it won't be the only incredible laser in the facility. The High Energy Density Science instrument, which will be used to research extreme states of matter, will use a special laser, Dipole, to create conditions similar to those found in the cores of planets inside and outside our Solar System.

Contributed by the Science and Technology Facilities Council in the UK through an international user consortium, the Dipole optical laser is designed to quickly provide a large amount of energy (ten 100-joule pulses per second, meaning each pulse has enough energy to lift a kilogram weight 10 metres high). That kind of energy, delivered in pulses lasting only nanoseconds, can compress matter in a way that generates energy-dense plasma for just long enough for the X-rays from European XFEL to interact with it. Scientists can then analyse the resulting data and learn about matter deep within other planets without ever leaving Earth.

European XFEL is a research facility currently under construction in the Hamburg area in Germany. Its extremely intense X-ray flashes will be used by researchers from all over the world. Learn more at: www.xfel.eu

For a list of European XFEL-related articles in *Science in School*, see: www.scienceinschool.org/xfel

A levitating
superconductor



ILL

Delving into superconductivity with polarised neutrons

Superconductivity is when electricity flows with no resistance and no energy loss. High-temperature superconductors can show superconductivity up to around 130 K. But even after 30 years of extensive research, understanding how materials become superconductors remains one of the single most important challenges. Researchers at the Institut Laue-Langevin (ILL) might now have found some answers.

There is a general consensus that the key to unravelling superconductivity may lie in what happens just before a material becomes superconducting, known as the pseudo-gap phase. In this phase, a material has a partial energy gap – it is conducting in some places but not in others. One possible explanation for this behaviour has been that the unit cells of the material, the repeating units that make up the structure, may contain small loop currents. As we know, electrical currents generate magnetic fields, but checking for such magnetic fields in this instance is difficult because the fields in question are tiny. Such fields, however, can be measured using neutrons.

Magnetic moments within the pseudo-gap phase of high-temperature superconductors have been detected, but questions remained. Researchers from ILL and the Laboratoire Léon Brillouin, in Gif-sur-Yvette, France, used polarised neutron diffraction to measure the magnetic signals in a high-temperature superconductor. They determined the magnitude and direction of these tiny magnetic moments and the extent to which they are correlated in space, and all as a function of temperature. These results form a set of conditions to describe the physics of the pseudo-gap phase and provide a better description of the postulated loop currents.

ILL is an international research centre at the leading edge of neutron science and technology. To learn more, see: www.ill.eu

For a list of ILL-related articles in *Science in School*, see: www.scienceinschool.org/ill



CC BY-NC-ND

Laughing is universal.

Image courtesy of Ian Kralic Camera; image

Learning from laughter

Neuroscientist and stand-up comic Sophie Scott explains the complexity and social importance of laughter.

By Laura Howes

How do you get an auditorium full of scientists to laugh? For Sophie Scott, the answer is simple: you play audio clips of people laughing uncontrollably and the reaction is infectious. But for Sophie, this is more than just a useful way to break the ice with her audience. She works on the neuroscience of laughter at University College London (UCL) in the UK. Her research looks at the physical process of laughing and also its social role and how we use laughter to mediate relationships. Laughter isn't just funny, she says, it's also incredibly useful. Imagine you have travelled to a foreign country where

you don't know the language or the culture; how do you communicate? It turns out that there are very few universal expressions and exclamations. Most people will recognise an expression of fear or distaste, but joy? Pleasure? One positive emotion that Sophie has shown to be universal is laughter. On the savannah of Africa, during Sophie's research, when a hunter feels silly or embarrassed he begins to laugh and soon he and Sophie's research team are laughing together. Back in the auditorium, Sophie uses audio clips to get us laughing. It is not just the audio track that's making us laugh,



REVIEW

- ✓ Biology
- ✓ Chemistry
- ✓ Psychology
- ✓ Music
- ✓ Social sciences
- ✓ Relations in class and in school
- ✓ Social media
- ✓ ICT
- ✓ All ages

As teachers, we must be familiar with emotions and human interactions and how they affect learning and the social climate in school. Laughter is one such interaction where we can benefit from new findings in neuroscience. The findings reported here can be used both for teachers' professional development and directly in lessons, for instance in interdisciplinary collaborations between biology, chemistry, psychology and social sciences. The science of laughter could be addressed in a discussion about human interactions and emotions, something we usually do very early in school. The different types of laughter can be discussed using emojis and photos with younger students, and more abstractly

and using neuroscientific data with older students. I would suggest that teachers experiment together with the students on the topic of basic emotions and then compare their outcomes with the reported research results. How do we differentiate between 'fake' laughs and 'real' laughs? Can we accurately interpret the difference with our friends? Can a computer analyse sound data to determine if the recorded laughter is real or faked?

Ingela Bursjö, Johannebergsskolan,
Gothenburg, Sweden

she says, but also the reactions of our neighbours and colleagues sitting next to us. We might think that we laugh at jokes, but we laugh mainly to interact with other people – a trait that extends across mammalian species, from primates to rats, for whom laughter is associated with play and tickling, just like with us. "It's a very social behaviour," Sophie explains. We

interact with people by talking, which is a solely human skill, but then we use a very old mammalian behaviour, laughter, to show people that we like them.

If you ever hear someone laugh, says Sophie, your brain activates neurons and gets ready to laugh as well, because we are primed to join in. There are two types of laughter – the truly involuntary

laughter during which you can hardly breathe, and a 'fake' kind used as a social lubricant – and Sophie has shown that the brain activation still responds to 'fake' laughter. This is true even though the two types have different physical and neurological signals and we can tell the difference between the two. Sophie's research has shown not only that both types of laughter trigger neurons prompting us to join in, but also that 'fake' laughter prompts our brains to try and understand why the person is laughing and how we should respond.

So laughter is a social tool that we use to convey different emotions, to bond with people and to signify that we are not a threat. And, says Sophie, although we can tell the difference between 'fake' and 'real' laughter, the 'fake' laughter is still useful for these social roles.

Sophie recalls an incident she recently saw on the train to illustrate her point. Two men sat down at a table on the train, joining a woman who was working. The woman got up to move away, but as she was explaining why

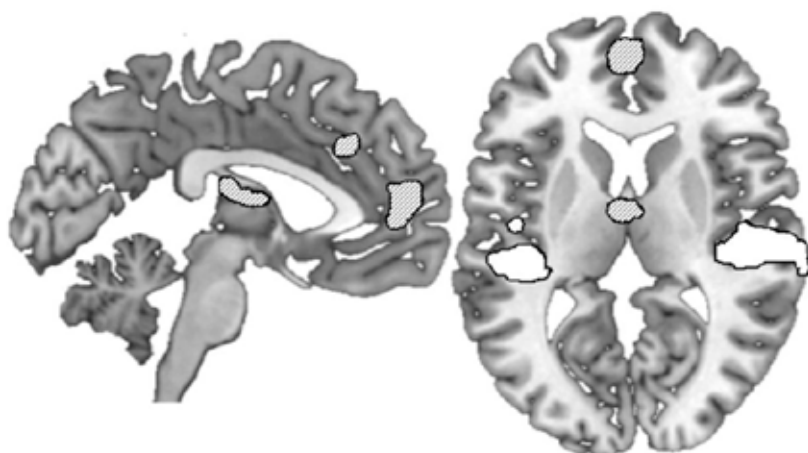

Image courtesy of McGettigan et al 2013

'Real' (white areas) and 'fake' (shaded) laughter activate different areas of the brain.

(she said she didn't like the smell of the men's coffee), she laughed and so made them laugh as well. This, says Sophie, was the perfect way to defuse the situation and make sure that she didn't offend the two men. Yet, says Sophie, she is sure that if she had asked any of the people involved, they wouldn't have remembered the laughter at all. According to Sophie, we all

underestimate how much we laugh even though we use laughter every day to promote bonding and de-escalate confrontations and negative emotions. For those of us who talk about liking people who make us laugh, Sophie has a revealing takeaway message. Rather than liking people because they make us laugh, perhaps we laugh with them because we already like them.

Understanding the behavioural and neurobiological bases of laughter, says Sophie, means more than thinking about jokes. It could provide a vital link between human language, relationships and emotional states. So don't just ask for someone with a good sense of humour when writing your dating profile; pay attention to see if you and your date enjoy laughing together.



Physical basis of laughter

Comparing normal breathing, laughing and speaking. The upper panels show the amplitude of the sound, the middle panel shows the frequency, and the lower panel shows the chest expansion.

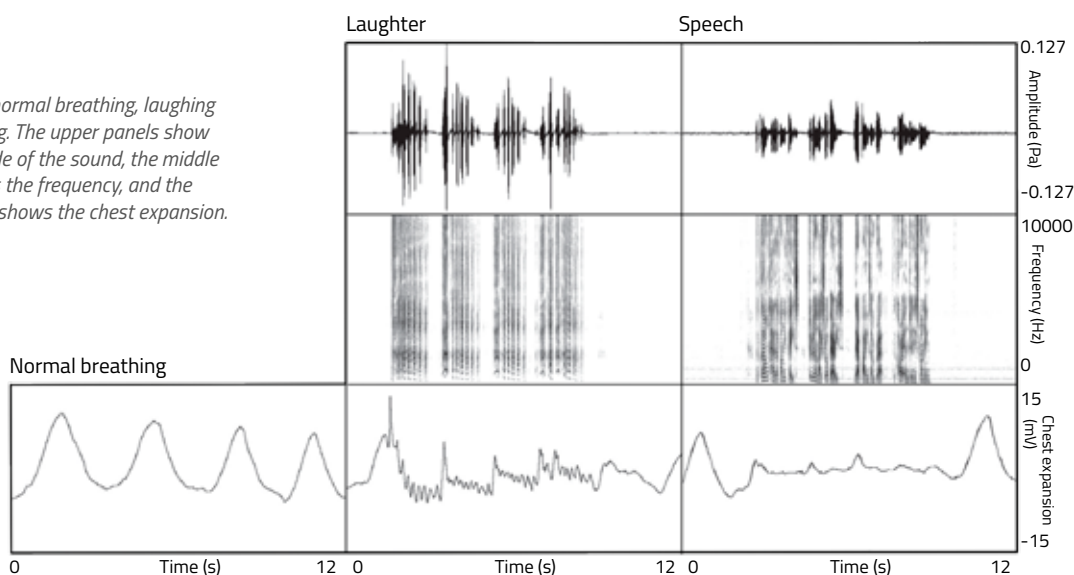

Image courtesy of Scott et al 2014

BACKGROUND

To understand laughter, says Sophie, you can't look just at the brain. You have to look at a part of the body that psychologists and neuroscientists don't normally spend much time looking at: the ribcage. You use your ribcage all the time to breathe. You use the intercostal muscles, the muscles between your ribs, to bring air in and out of your lungs by expanding and contracting your ribcage, and that movement follows a gentle sinusoidal pattern. As soon as you start talking, you breathe completely differently, with very fine movements of the ribcage squeezing the air out.

But breathing can be interrupted by laughter. When you laugh the intercostal muscles start to contract very regularly, and you get a very marked sort of zig-zag squeezing. Each of those contractions gives you a sound – "Ha!" As the contractions run together, you can get

spasms and wheezing. Listen to your friends laugh and you'll notice that they reach much higher pitches than they normally can because of the force of the air being expelled by the lungs. These pitches increase as the physiological arousal in the person laughing increases. It can also lead to wheezes, snorts, grunts and whistles. Just as different parts of the brain prompt 'fake' and involuntary laughter, Sophie's research has found several acoustic and phonetic differences between 'fake' social laughter and involuntary mirthful laughter. Some of these differences link directly to the greater forces generated during the involuntary laughter, which are extremely hard to produce voluntarily. Sophie believes that this suggests 'fake' laughs are not necessarily simply weaker forms of 'real' laughs, but have their own clear markers, reflecting their social importance.



Image courtesy of Alon; image source: Flickr

Image courtesy of Sumon Mallick; image source, Wikimedia Commons



Sophie Scott

References

McGettigan C et al (2013) Individual differences in laughter perception reveal roles for mentalizing and sensorimotor systems in the evaluation of emotional authenticity. *Cerebral Cortex* **25**: 246–257. doi: 10.1093/cercor/bht227

Scott S et al (2014) The social life of laughter. *Trends in Cognitive Sciences* **18**(12): 618–620. doi: 10.1016/j.tics.2014.09.002

Resources

Sophie recently presented a TED talk called ‘Why we laugh’. To watch a video of her talk, see: www.ted.com/talks/sophie_scott_why_we_laugh?

For a longer talk on ‘The Science of Laughter’, watch Sophie’s lecture at the Royal Institution, UK: www.youtube.com/watch?v=4BWRoHGiwrw

Sophie also wrote an article about some of the difficulties in getting people to laugh for science:

Scott S (2014) Beyond a joke: how to study laughter. *The Guardian* (UK) 10 July. www.theguardian.com or use the direct link: <http://tinyurl.com/khrp4g5>

Medical research related to energy and metabolism can be relevant to further discussion with your students. For example, see:

Buchowski MS et al (2005) Energy expenditure of genuine laughter. *International Journal of Obesity* **31**: 131–137. doi: 10.1038/sj.ijo.0803353

Other research has also shown that male and female brains respond differently to humour. To find out more, read:

Hayes E (2010) The science of humour: Allan Reiss. *Science in School* **17**: 8–10. www.scienceinschool.org/2010/issue17/allanreiss

Laura Howes is one of the editors of *Science in School*. She studied chemistry at the University of Oxford, UK, and then joined a learned society in the UK to begin working in science publishing and journalism. In 2013, Laura moved to Germany and the European Molecular Biology Laboratory to join *Science in School*.



CC BY-NC-ND



Planetary energy budgets

Understanding Earth's climate system can teach us about other planets.

By Sylvia Knight

Climate change and climate modelling are continually in the news. One way of testing how well we understand Earth's climate system is to see how well we can apply our knowledge to other planets with very different climates. Films like this year's *The Martian* depict other planets in our Solar System as inhospitable. What, though, are they really like and how do their atmospheric compositions affect them?

From the point of view of an individual standing on the surface, Earth's air, ice, water and soil, can seem like independent entities. However, the different elements of the climate system – atmosphere, cryosphere, oceans and land – are not isolated; they exchange huge amounts of energy and influence each other's behaviour. The fragile balance – Earth's energy budget – is calculated as the sum of all energy inputs into the climate system minus all energy leaks. If all inputs and outputs are equal, the global temperature is held constant, but if anything happens to tip the balance – such as an increase in the amount of greenhouse gases in the atmosphere – then the temperature changes (see Shallcross & Harrison, 2008).

Earth's energy

The Sun's electromagnetic radiation takes eight minutes to reach Earth, and is the major source of energy on Earth – as it is for all planets in the Solar System. As we follow the Sun's energy into Earth's atmosphere, we can see how it feeds into the planet's climate system, with its complicated energy flows and feedback loops. This information is captured in charts that have come to be known as Trenberth diagrams (figures 1, 2 and 3 on page 14; Trenberth et al, 2009).

As the Sun's radiation passes through Earth's atmosphere, much of the incoming ultraviolet radiation is absorbed by ozone in the stratosphere, approximately 10–50 km above Earth's surface. More solar radiation is then reflected and scattered by clouds and small particles in the atmosphere (known as aerosols). When dust accumulates in the

atmosphere as a consequence of huge volcanic activity, still more of the Sun's radiation is scattered away from the surface of Earth. This occurred in 1816, the year without summer, when the 1815 eruption of Mount Tambora in the Dutch East Indies (now known as Indonesia) caused a volcanic winter and major food shortages across the northern hemisphere.

Even more of the Sun's radiation is reflected by Earth's surface and is described by the albedo, which is calculated as the ratio of reflected radiation to incident radiation. Light-coloured surfaces such as ice have a higher albedo than darker ones. You can demonstrate how albedo works by using two ice cream tubs and painting the inside of one black, putting a thermometer in each tub and then covering them with clear plastic food wrap. Left in the sun, or under a lamp, the dark tub will absorb radiation and warm up while the white one will reflect the radiation and remain cooler.

The energy that reaches the surface of Earth heats it and is re-radiated (for an explanation of black-body radiation, see Ribeiro, 2015). Some energy also returns to the atmosphere by conduction and convection as well as by the evaporation and transpiration of water – some of which later condenses in the atmosphere to form cloud droplets, releasing latent heat as it changes state.

Greenhouse gases also absorb some wavelengths of the infrared radiation emitted from the surface of Earth. Some of this is then emitted upwards and lost to space, but most is directed back towards Earth's surface. Other wavelengths of outgoing infrared radiation are not absorbed by any atmospheric gas and escape to space unhindered.

The balance

Earth's energy budget explains how the global temperature can change in one direction or another. Noticeably, the total amount of solar radiation reaching Earth is not always the same because of changes in the activity of the Sun (which

Sea ice plays a central role in our climate and global ocean circulation.



follows roughly 11-year cycles and can also change over longer time periods). Changes in Earth's orbit around the Sun also affect which parts of Earth receive more energy – which has consequences for global climate.

After balancing out these factors (by averaging the input and output radiation across all the days of the year, and across the whole of the planet), we get the amount of energy that Earth gains from or loses to space. Using the Trenberth diagram (figure 1), you could ask your students to add or subtract these different values. Their answers should show that slightly more energy (about 0.6 Wm^{-2}) is currently coming in than is going out, so the climate system is heating up^{w2}.

Mars's energy

Further away from the Sun is one of our closest neighbours in the Solar System. four minutes after reaching Earth and 12 minutes after leaving the Sun, solar energy arrives at Mars. The red planet is half the size of Earth but the two planets have a similar rotation rate and tilted axis, so they also have similar seasonal variations in climate and atmospheric circulation. Mars's weather is dominated by dust storms, the carbon and water cycles, and thermal tides driven by the movement of the Sun's radiation.

However, the thin atmosphere of Mars



REVIEW

- ✓ Biology
- ✓ Geography
- ✓ Ages 11–19

'Global warming', 'ozone layer depletion', 'climate change' – we are constantly bombarded with these buzzwords by the Web, TV programmes, environmentalists and scientists. However, the scientific reasons why our planet is not budgeting its energy inputs and outputs well are sometimes left unsaid. This article is an excellent resource for understanding the reasons behind the fact that our planet is retaining more energy than it is radiating – hence rising temperatures. It also provides an insight into why the same thing may not be happening on our neighbouring planets.

Apart from being used as a comprehension exercise with students, this article can help to raise awareness about our role in all of this. Potential discussion questions include:

- How do Earth's atmospheric layers affect the light rays reaching us from the Sun?
- What affects the balance between energy inputs and energy outputs on Earth?
- How do the climates of neighbouring planets differ from our planet?
- Could the climate of these planets be adapted for human survival?
- What is the extent of human impact on our climate?
- How has this impact changed over the years?
- What is our responsibility towards present and future generations?
- What can we do to leave a better planet than we've inherited?

Catherine Cutajar, St. Martin's College Sixth Form, Malta

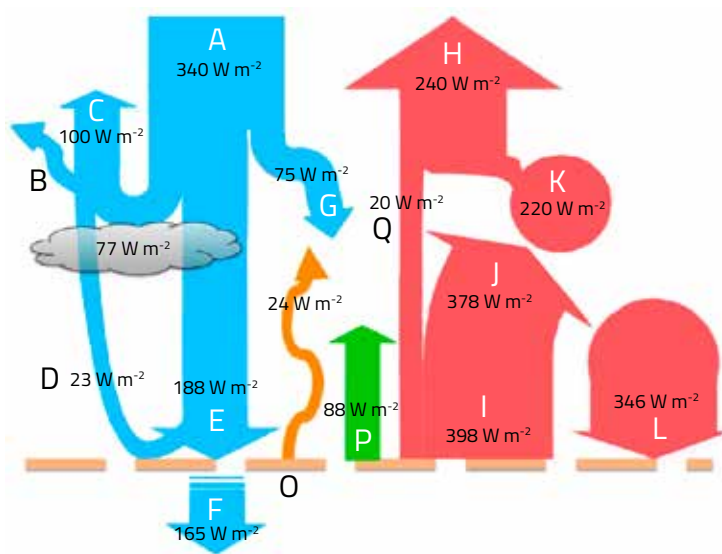

Figure 1: The energy budget of Earth, averaged over Earth's surface and over the year. Solar radiative fluxes are shown in blue and infrared fluxes in pink; convective fluxes are shown in orange.

- A: Incoming solar radiation;
- B: Scattered by clouds and atmosphere;
- C: Total shortwave radiation reflected to space;
- D: Reflected by surface;
- E: Shortwave radiation that reaches surface;
- F: Shortwave radiation absorbed by surface;
- G: Shortwave radiation Absorbed by atmosphere;
- H: Total outgoing infrared (longwave) radiation;
- I: Longwave radiation emitted by surface;
- J: Longwave radiation absorbed by the surface;
- K: Longwave radiation emitted by atmosphere to space;
- L: Longwave radiation emitted by atmosphere to surface;
- O: Thermals;
- P: Evapotranspiration;
- Q: Longwave flux from surface to space.

Images courtesy of Sylvia Knight

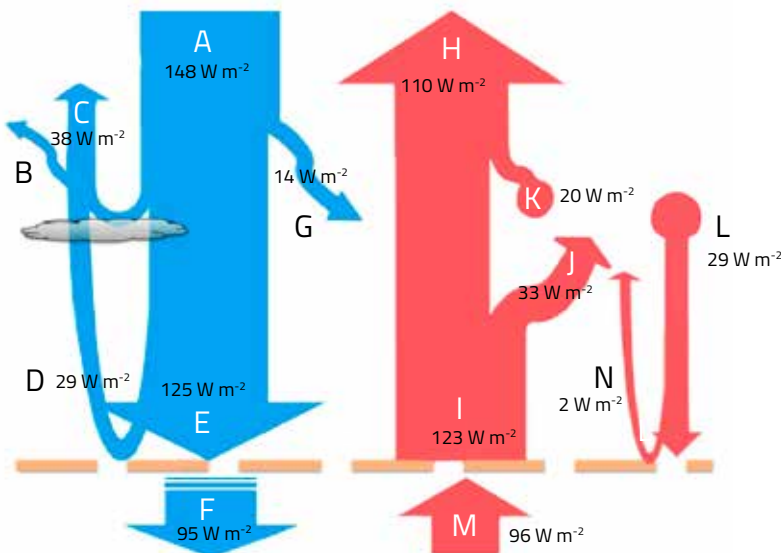

Figure 2: Mars's energy budget under relatively low dust conditions. When there isn't a dust storm, Mars's atmosphere has very little impact on the flow of energy into and out of the planet.

- A: Incoming solar radiation;
- B: Scattered by clouds and atmosphere;
- C: Total shortwave radiation reflected to space;
- D: Reflected by surface;
- E: Shortwave radiation that reaches surface;
- F: Shortwave radiation absorbed by surface;
- G: Shortwave radiation Absorbed by atmosphere;
- H: Total outgoing infrared (longwave) radiation;
- I: Longwave radiation emitted by surface;
- J: Longwave radiation absorbed by the surface;
- K: Longwave radiation emitted by atmosphere to space;
- L: Longwave radiation emitted by atmosphere to surface;
- M: Longwave radiation emitted by surface;
- N: Longwave radiation reflected by the surface.

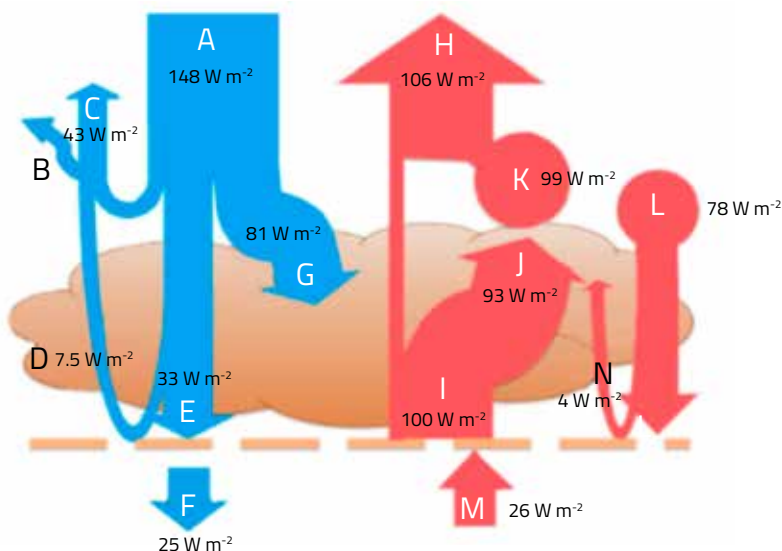

Figure 3 Mars's energy budget during major dust storms. The dust absorbs much of the incoming sunlight and creates an anti-greenhouse effect, with more heat escaping from the top of the atmosphere than leaves the surface.

- A: Incoming solar radiation;
- B: Scattered by clouds and atmosphere;
- C: Total shortwave radiation reflected to space;
- D: Reflected by surface;
- E: Shortwave radiation that reaches surface;
- F: Shortwave radiation absorbed by surface;
- G: Shortwave radiation Absorbed by atmosphere;
- H: Total outgoing infrared (longwave) radiation;
- I: Longwave radiation emitted by surface;
- J: Longwave radiation absorbed by the surface;
- K: Longwave radiation emitted by atmosphere to space;
- L: Longwave radiation emitted by atmosphere to surface;
- M: Longwave radiation emitted by surface;
- N: Longwave radiation reflected by the surface;



The south pole of Mars, capped with frozen water and carbon dioxide

Image courtesy of ESA/DLR/FU Berlin

has little effect on radiation passing through it. This means that almost all the incoming radiation reaches the planet's surface, but then almost all its emitted radiation escapes to space. This is due to the fact that the Martian atmosphere contains much more carbon dioxide than Earth's, and hardly any other greenhouse gases. Whilst the relatively narrow band of emitted radiation at a wavelength of 15 μm is almost entirely absorbed by the carbon dioxide in the atmosphere, the rest of Mars's black body emission escapes and Mars's greenhouse effect only warms the planet's surface by 5 K per year. In the typical Martian winter, temperatures can be low enough (140 K) for carbon dioxide to condense, forming snow around both its poles and further increasing the planet's albedo. Things change dramatically in the Martian atmosphere every 3–5 years when a major dust storm leaves the sky a reddish-brown and dust clouds reflect or absorb up to 78% of the Sun's radiation. The absorbed solar radiation is emitted as heat in the atmosphere,

producing an anti-greenhouse effect as more infrared radiation is lost from the top of the atmosphere than is emitted by the surface. The atmosphere warms as the surface cools; as the surface cools, surface winds fall and low-level convection switches off, removing the source of dust and triggering the storm's decay.

The importance of our atmosphere

The energy flows through planetary atmospheres in our Solar System are as different as the planets themselves (a description of the climate of Venus, Titan and Jupiter can be downloaded from the *Science in School* website^{w3}). Planets such as Earth and Venus have gases that produce a greenhouse effect, which has a significant influence on their climate; other planets, such as Mars (when dusty) and Jupiter, have an anti-greenhouse effect. Together with liquid water and a living ecosystem, we humans complicate Earth's climate system further. However, although

we are slowly altering the energy balance on Earth, we would not be able to survive without our atmosphere trapping the solar energy and warming up our little blue planet. The more we understand how these complicated systems work, the closer we can come to understanding our impact on Earth.

References

Ribeiro CI (2015) Starlight inside a light bulb. *Science in School* **31**: 37–42. www.scienceinschool.org/2015/issue31/black_body

Shallcross D, Harrison T (2008) Climate change modelling in the classroom. *Science in School* **9**: 28–33. www.scienceinschool.org/2008/issue9/climate

Trenberth KE, Fasullo JT, Kiehl J (2009) Earth's global energy budget. *Bulletin of the American Meteorological Society* **90**: 311–323. doi: 10.1175/2008BAMS2634.1

Web references

- w1 You can learn more about how Earth generates its own heat by reading *National Geographic's* education web page on geothermal energy. See: <http://education.nationalgeographic.com/encyclopedia/geothermal-energy>
- w2 The Metlink website provides support and materials for teaching weather and science. For updates on the 2013 Intergovernmental Panel on Climate Change report for science teachers, see: www.metlink.org/climate/pcc-updates-science-teachers/#1
- w3 A description of the climates of Venus, Titan and Jupiter can be downloaded from the *Science in School* website. See: www.scienceinschool.org/2015/issue34energy

Resources

The MetLink website is full of teaching resources and activities for teachers. The 'Why is the sky blue', 'Scatter UV light' and 'Reflective surfaces' activities all support this article and can be found at <http://www.metlink.org/experimentsdemonstrations>

For a series of *Science in School* articles about climate change, see: www.scienceinschool.org/climatechange

Dr Sylvia Knight is a meteorologist with a particular interest in climate modelling. She is head of education services for the Royal Meteorological Society in the UK.





A safari in your mouth's microbial jungle

Image courtesy of Shutterstock / Concept Photo

A citizen science project travelled over 7000 km to explore the microbial population in students' mouths.

By Jose Viosca

Pulling your lips away, you open your eyes, smiling into the beautiful eyes in front of you. But that kiss hasn't just left you both with a warm feeling, a shared moment; that kiss has also swapped microbes from one mouth to the other. It might sound disgusting, but each kiss – along with each cigarette, meal or object that you put in your mouth – can subtly alter the microbial population in your mouth, and ultimately your health.

For two and a half months in 2015, researcher Luis Bejarano travelled more than 7000 kilometres around Spain collecting saliva samples from 15-year-olds in 40 schools for a research project called *Saca la lengua* (Stick your tongue out^{w1}). With just a van equipped with a centrifuge and a freezer, Bejarano collected over 1600 samples. "It's the longest business trip I've ever done," Luis smiles.

"Our goal is to understand the link between specific behaviours or environments and certain micro-organisms," explains Toni Gabaldon, who leads the research group in which Luis works, at the Center for Genomic Regulation in Barcelona, Spain. To this end, his team is creating a catalogue of students' habits and the micro-organisms found in their mouths, including bacteria and fungi.

The project not only involves the students in real research but also provides a huge sample set for the researchers. "Thanks to students' co-operation, we are carrying out one of the largest-scale studies of mouth microbes done to date," adds Luis.

A microbial jungle

Single-celled organisms, including bacteria, were first discovered in the 17th century by the Dutch tradesman and scientist Antonie van Leeuwenhoek when he looked down a microscope at his own saliva and plaque. Today we know that our mouths are a real jungle: a neighbourhood of co-existing species that scientists term the oral microbiome. Every millilitre of saliva contains around 140 million microbes, and there are more than 700 different species in your mouth alone.

In fact, microbes are an integral part of us, inside and out, and we are all home to a huge number of them. At a total weight of around 1.5 kilograms, the microbes in the mouth, gut and skin make up 90% of all the cells in our body (He et al, 2014). In some ways we are more microbiome than human.

The balance between these different microbes is constantly in flux, and fights between microbes are common: the antibiotics that now save lives across the world are based on the weapons that microbes use to compete with each other for territory and food.

Scientists are discovering that the mouth microbiome not only contains microbes that cause tooth decay, but also is clearly linked to various conditions including pancreatic cancer, atherosclerosis (a type of heart disease), diabetes and obesity (see box on p 18 and He et al, 2015). Are the

Image courtesy of Luis Bejarano



Luis in the lab

microbes in the mouth the cause or consequence of these diseases? And how do the micro-organisms influence distant organs? Scientists don't yet know the answers to these questions, but if the oral microbiome changes during the early stages of disease, detecting these changes with a saliva test could help doctors diagnose these conditions with a very simple sampling method: a mouthwash. It was these questions that took Luis out onto the road, visiting high schools and asking for students' help – and their spit.

'Stick your tongue out'

Luis spent three to four hours in each school, explaining the research project and talking about the life of a scientist. "I tried to show the students that science can be a lot of fun," he explains, adding, "I myself enjoy working in the lab a lot." After the introduction, student volunteers filled in an anonymous survey with lifestyle questions. Many of these questions came from students themselves who, months earlier, had helped define the lifestyle variables to be sampled and analysed. Through this collective brainstorming, scientists collected data on a number of interesting habits such as nail biting, pen biting or mouth kissing, none of which they had originally thought to include. The students then briefly rinsed their mouths with a saline buffer (a pH-controlled solution) and spat into a test tube to provide their sample.

Back in the lab, the researchers have to be creative to identify all the microbial species in each sample. "Classically, the study of micro-organisms is done by culturing them on a dish in the lab,"

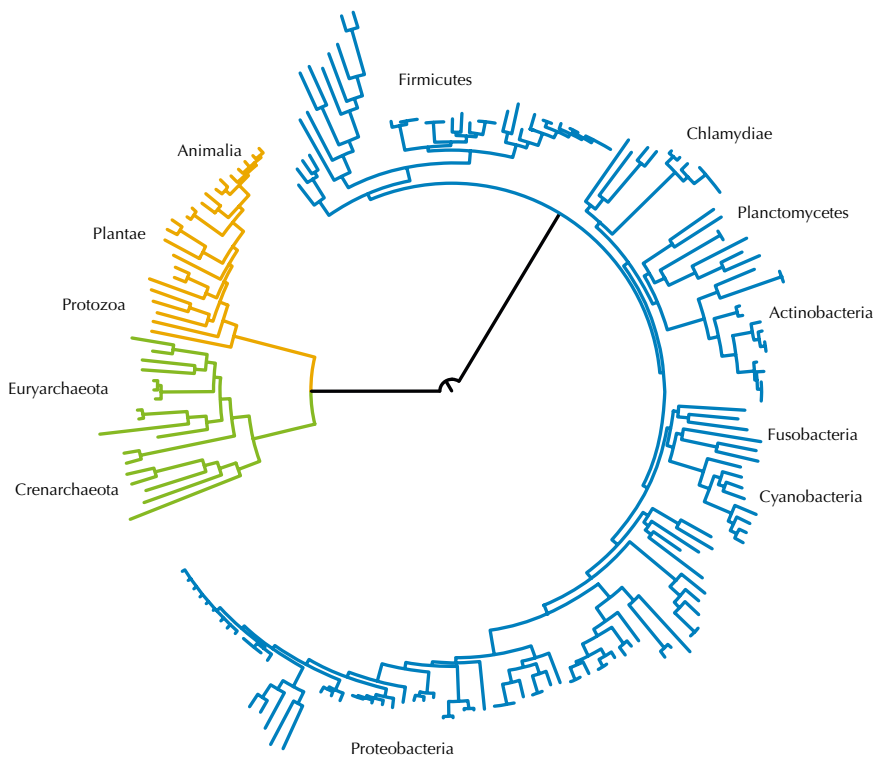

Evolutionary tree of life, showing all branches (current species and groups of organisms) derived from the common ancestor. Animals and plants are shown in orange. Microbes are found in all colour groups: blue, green and orange.



- ✓ Biology
- ✓ Health
- ✓ Hygiene
- ✓ The scientific method
- ✓ Age 11+

REVIEW

This article is a perfect starting point for introducing biology as a science and as a connection between all major science subjects, including mathematics. The essence is that biology is the centre of a network in which all other sciences can be linked. Such a network is necessary to explain a wide variety of natural phenomena, and the article proves that one has to use many approaches from different sciences to come to a conclusion.

Secondary-school teachers could use the article as an introduction to the first year of biology onwards, which lends itself to student-centred teaching. The teacher could also guide students to read a scientific paper as part of a comprehension exercise, allowing the students to understand the data and formulate questions to explore the research topics, bouncing questions and answers between them. Discussion topics could be developed by the students, and the teacher should refrain from interfering too much – except to set facts straight.

Friedlinde Krotscheck,
Austria



Mouth microbes: the good, the bad and the ugly

While researchers are still piecing together the complex microbiome from all of the samples collected in Spain this year, we already know that an excess or lack of certain microbes in the mouth is associated with various phenomena.

- On the teeth: *Streptococcus mutans* and several other bacteria cause cavities, but some other *Streptococcus spp.* prevent the colonisation of microbes that cause periodontitis (gum disease). Smoking is known to be an important risk factor for periodontitis, possibly because it impairs this protective function of *Streptococcus spp.* (He et al, 2015).
- On the tongue: bad breath (halitosis) is the consequence of volatile sulfur compounds and malodorous fatty acids produced during the decomposition of amino acids and proteins by several microbes (*Solobacterium moorei*, *Atopobium parvulum* and *Eubacterium sulci*). People with halitosis also lack some microbes that are normally present on the tongue, including *Streptococcus salivarius* and *Rothia mucilaginosa* (He, 2015).
- In the saliva: the presence of *Neisseria elongata* and *Streptococcus mitis* might predict the presence of pancreatic cancer with 80–90% accuracy (Michaud & Izard, 2014), and *Selenomonas noxia* has been linked with obesity (Yoshizawa et al, 2013).

says Toni, “but this is not possible with around 50% of the microbes that live in the mouth: they just don’t grow.” Instead, the team turned to genomic analysis to identify all the species by using the microbes’ DNA. The team will look for specific, characteristic DNA sequences and compare these across organisms to determine what species are in each mouth.

Luis’s sampling adventure ended in April 2015 and since then the laboratory has been busy processing the samples to obtain and read the genomic data. Students and the wider public are now helping with the analysis and interpretation of the data, from performing statistical analysis of the survey responses and proposing new ways to visualise the collected data, to performing bioinformatics analysis similar to that described in Tenorio (2014). Those participants providing insights may appear as authors on the resulting research papers, as well as winning a trip to Barcelona in 2016 to visit the lab itself.

“I think the students who took part in this project enjoyed it a lot: it was a completely new and different activity,” concludes Luis. If nothing else, the students will have a much clearer idea of what it means to kiss someone, microbially speaking.



On the road

References

- Chambers PJ, Pretorius IS (2010) Fermenting knowledge: the history of winemaking, science and yeast research. *EMBO reports* **11**: 914–920. doi: 10.1038/embor.2010.179
- He J et al (2015) The oral microbiome diversity and its relation to human diseases. *Folia Microbiologica* **60**: 69–80. doi: 10.1007/s12223-014-0342-2
- Michaud DS, Izard J (2014) Microbiota, oral microbiome, and pancreatic cancer. *Cancer Journal* **20(3)**: 203–206. doi: 10.1097/PPO.0000000000000046
- Tenorio G (2014) Using biological databases to teach evolution and biochemistry. *Science in School* **31**: 30–34. www.scienceinschool.org/2014/issue29/online_bioinf
- Yoshizawa JM et al (2013) Salivary biomarkers: toward future clinical and diagnostic Utilities. *Clinical Microbiology Reviews* **26(4)**: 781–791. doi: 10.1128/CMR.00021-13

Web reference

- w1 For up-to-date information on the progress of the ‘Stick your tongue out’ project (in Spanish), visit: www.sacalalengua.org

Jose Viosca is a neuroscientist turned science communicator, with an interest in people, science education and everything that catches his attention. After postdoctoral research at the European Molecular Biology Laboratory in Monterotondo, Italy, he moved to *Science in School* for an editorial internship. Find him on Twitter: @jviosca



Model of the human brain as seen from inside, where the secrets of our learning lie

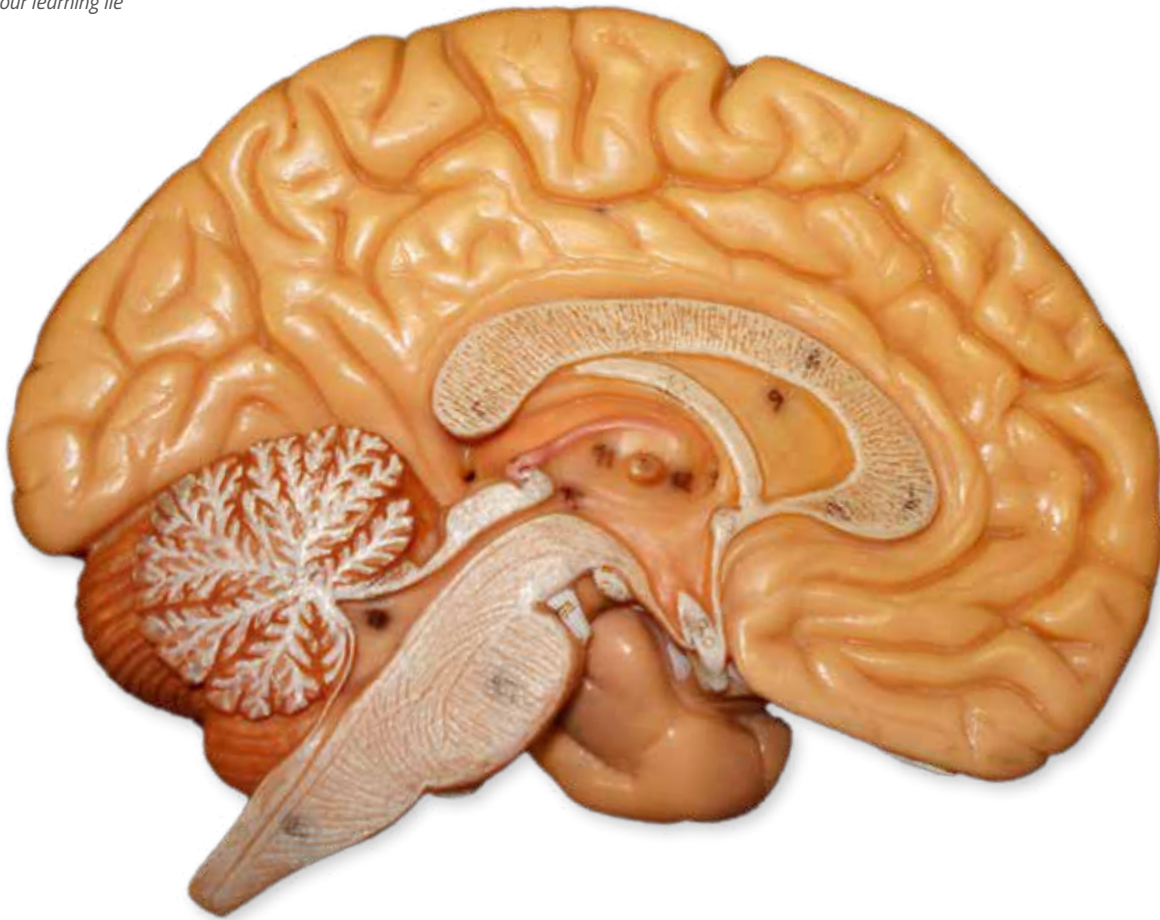

Image courtesy of biologycorner; image source: Flickr

How neuroscience is helping us to understand attention and memory

How electrodes placed directly in the brain are teaching us about learning.

By Gary Finnegan

“There is a war in our brains,” says neuroscientist Jean-Philippe Lachaux, research director at the French National Health Research Institute (Inserm) in Lyon, France. “It is a competition between the habit system, which allocates attention based on fixed rules and experience, the reward system, and the executive system, mainly located in the frontal lobe.”

When faced with multiple activities, these systems combine to produce a map of priorities. If you want to concentrate on writing a report, solving a puzzle, having a conversation or reading a long article, you want your executive system to win the war. But with so much external stimulation – from smart phones and noisy ringtones to TV shows and eye-catching billboards – it can be difficult to focus on your task.

Lachaux wants to figure out which neural networks within these brain systems react when we are distracted. A deeper understanding of what is going on when we lose concentration could help neuroscientists to train people to resist distraction.

Much of the work in this area has been on ‘zoning out’ or mind-wandering. What Lachaux and his team are interested in, however, is ‘micro mind-wandering’: those brief flickers of distraction we experience when someone’s phone rings while we are doing a crossword puzzle. “With micro mind-wandering you don’t totally lose track but you experience interference,” said Lachaux. “For a couple of seconds, you are suddenly multitasking.”

At Lachaux’s lab in Lyon, they have a somewhat unorthodox approach – intracranial electroencephalogram (EEG). This technique involves an operation under general anaesthetic to place electrodes directly on the surface or deep within the brain of the patients. To use such an invasive technique for purely research purposes would, of course, raise serious ethical questions. Lachaux’s study, however, was performed on patients with epilepsy who – for therapeutic reasons unconnected with the study – were connected to intracranial EEG for two weeks. The subjects were asked to concentrate on performing a task on an iPad and then observing what happens when they are distracted, for example, by a ringing telephone.

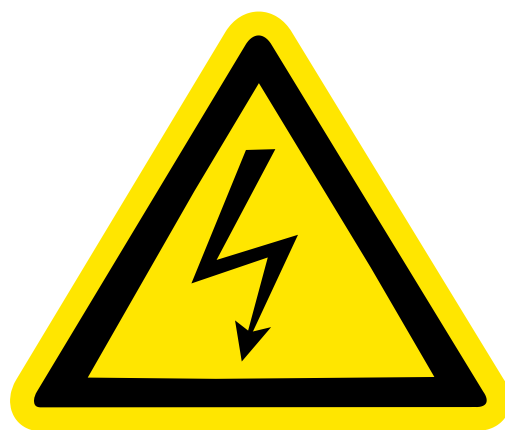

This symbol represents high-voltage danger, but in the experiment, participants received an unpleasant but otherwise safe electric shock.

Electroencephalogram data showing brain activity ripples

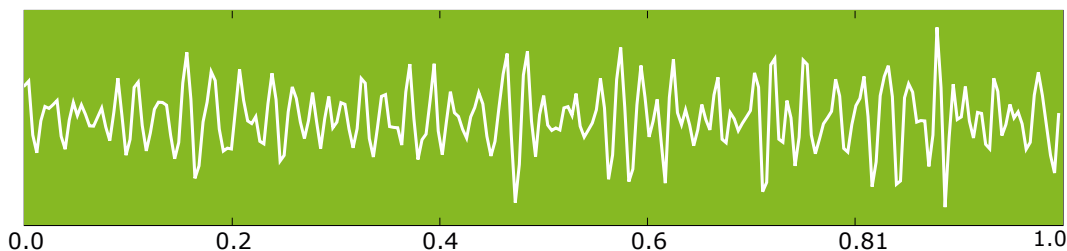

In a typical electroencephalogram experiment, a helmet with dozens of electrodes is placed on top of the skull surface.



Image courtesy of Duesentrieb; image source: Wikimedia Commons

Image courtesy of Hugo Gambo; image source: Wikimedia Commons

Image courtesy of Csaba Segešvári; image source: Wikimedia Commons

Image courtesy of Iria Flavia Spanish Courses; image source: Wikimedia Commons



Paying attention uses specific regions of the brain

other information we were receiving at the same time. The idea was that our brain was designed to focus on something emotional at the expense of other information.

However, Michiko Sakaki, a senior research fellow at the University of Reading, UK, says new findings from her research team suggest the reality may be more complex. "Arousal has different effects depending on priority. When people encounter emotional stimuli, it can enhance attention to particularly salient information to which we attach high priority."

Sakaki has been conducting controlled experiments on the interaction between emotion and cognition. To induce an emotional response, subjects receive electrical stimulation – which is unpleasant but not dangerous – while a high- or low-pitch tone is played (Lee et al, 2014). They soon learn to associate the tone with the small electric shock. Then researchers ask participants to play a memory game while listening to the dreaded tone. The task requires participants to remember various items with different salience (for example: faces, which are intrinsically relevant to humans, and places). The question is then how well the subjects perform the

memory task under the stress of fearing an electric shock.

"We found that participants' attention is affected by emotion and priority, such that they pay more attention to particularly vivid information or details that are highly relevant to them, but their retention of low-priority information is impaired," said Sakaki. Her team also found a similar pattern in participants' memory.

"This calls into question the traditional view that emotional arousal always impairs processing of other information," she said. "It is not so simple. Our notion that emotion enhances attention to, and retention of, high-priority information suggests that teachers could use positive emotional arousal in an educational setting to selectively enhance students' learning."

Acknowledgement

The original version of this article was published in *Horizon*, the EU research and innovation magazine^{w1}.

Reference

Lee TH et al (2014) Emotional arousal amplifies the effects of biased competition in the brain. *Social Cognitive and Affective Neuroscience* **9**: 2067–2077. doi: 10.1093/scan/nsu015

Web reference

w1 The original article can be read on the *Horizon* website. See: www.horizon-magazine.eu or use the direct link: <http://tinyurl.com/ppkp6jp>

Resources

To find out more about educational neuroscience and its use in the classroom, read:

Marytnoga B (2015) Can neuroscience solve the mystery of how students learn? *The Guardian (UK)*, 12 July. See: www.theguardian.com or use the direct link: <http://tinyurl.com/phzwwun>

For an example of using positive emotional stimulation in the classroom, see:

Molyneux C (2007) Using music in the science classroom. *Science in School* **5**: 32–35. www.scienceinschool.org/2007/issue5/music

Gary Finnegan has worked for 12 years as a magazine editor, newspaper columnist and a digital reporter, and is now an editorial consultant. He has a degree in physiology from Trinity College Dublin, Ireland, and an MSc in science communication from Dublin City University. He was a national winner of the EU Health Prize for Journalists in 2009, 2010 and 2011, and was voted Online Journalist of the Year and Opinion Columnist of the Year at the Irish Medical Media Awards in 2007 and 2013, respectively.



CC BY-NC-ND

Space for all the sciences: the ESA teachers workshop

In July 2015, 120 teachers from around Europe converged at ESA to learn how to use space as a context for broader teaching.

Teachers had the opportunity to experiment themselves during the many hands-on practical workshop sessions.

By Laura Howes

Noordwijk on the north coast of the Netherlands is not just home to windswept beaches. For three days in July 2015, it also hosted 120 European teachers who had come to learn about space.

The European Space Agency (ESA)'s European Space Research and Technology Centre (ESTEC) opened its doors to share classroom activities and to enable teachers to network. The 2015 summer teachers workshop was the largest yet, and for the first time, primary-school teachers were included on the guest list.

Head of the STEM Education and Outreach Unit at ESA (and *Science in School* editorial board member), Monica Talevi, welcomed the group and explained the purpose of the workshop. ESA's commitment to education is written into the agency's charter and ESA must put its findings into the service

of education. Yet that doesn't just mean physics education, as Talevi made clear: "There is no STEM [science, technology, engineering and maths] subject that can't be covered by space," she emphasised.

The workshop programme was built around five key topics – gravity, Rosetta, planet Earth, light, and human space exploration. Each session started with a plenary for all the teachers before the groups split into primary- and secondary-school sessions.

There was a great deal of excitement when eminent speakers such as Rosetta project scientist Matt Taylor, ESA astronaut André Kuipers, award-winning solar astrophysicist Pål Brekke, and ESA Copernicus space segment manager Guido Levrini gave talks, and teachers rushed up afterwards for photos and

Image courtesy of ESA/A.Conigli



Exploring Mars with Lego

autographs. But the real enthusiasm came during the sessions that followed, in which the teachers were given the opportunity to try the space-related activities for themselves.

For example, while primary-school teachers were making craters and talking more about how comets can be

'time capsules' in space, secondary-school teachers were busy cooking up their own comet from dry ice, carbon and Worcestershire sauce. All of the activities presented are, or will be, available from the ESA website as part of the 'Teach with Rosetta' project^{w1}. "We know that space science inspires," explained Anu Ojha, director of the National Space Academy in the UK, who presented some of the activities in the secondary-school sessions. "You can take many of these themes to teach fundamental topics from the physics, chemistry, biology and mathematics curricula across Europe."

One of the popular activities on the Teach with Rosetta website has been the 'Pixel your space' activity (see *Science in School*, 2015, 32, p3 for more details) which was done on a huge scale at

Image courtesy of ESA/A.Conigli



Splitting sunlight with CDs

Image courtesy of ESA/A.Conigli



The 'Pixel your space' activity was a great way to get to know each other.

Images courtesy of ESA/A.Conigli



Not being able to see or smell food gets you a sense of what it is like to eat in space



Images courtesy of ESA/A.Conigli



Noordwijk as an activity to encourage the participants to relax and get to know each other at the beginning of the workshop. Silence descended as 120 teachers got out their pencils, rulers and glue sticks to put together part of a huge image that eventually spread across the floor of the seminar room^{w2}. By the end of the workshop there was no stopping the networking. For the

teachers who wanted to continue what they started in Noordwijk, various online groups have been set up to continue the conversation. ESA also has space education resource offices around Europe (known as ESEROs) to help share resources and best practice^{w3}. "I'm looking forward to working with ESERO Ireland and Science Foundation Ireland to develop exciting workshops,"

said Irish primary-school teacher Carla Hayes.

European teachers will be invited to apply for the next workshop, taking place in Summer 2016. The workshop will be advertised on the ESA website and in *Science in School*. Priority will be given to those who have not attended before and to teachers who are committed to sharing what they have learned with their colleagues.

Web references

- w1 For more information on the "Teach with Rosetta" resources, visit the project's website: www.esa.int/Education/Teach_with_Rosetta/
- w2 You can watch a timelapse video of the 'Pixel your space' activity as part of the summary video from ESA: www.esa.int/Education/Teachers_Corner/Highlights2/ESA_Teachers_Workshop
- w3 For more information about the ESERO project, and to find your nearest office, visit: www.esa.int/Education/Teachers_Corner/About_the_ESERO_project

Laura Howes is one of the editors of *Science in School*. She studied chemistry at the University of Oxford, UK, and then joined a learned society in the UK to begin working in science publishing and journalism. In 2013, Laura moved to Germany and the European Molecular Biology Laboratory to join *Science in School*.



CC BY-NC-ND



The mathematician who became a biologist

Theodore Alexandrov is taking what he learned from working on the economy and applying it to the chemicals on our skin.

By Claire Ainsworth

You might not think that your body's biology has much in common with the workings of your credit card or the global banking system – and neither, at first, did Theodore Alexandrov. But Theodore is now using mathematical algorithms for understanding the economy to analyse information about the countless molecules produced by our cells.

Theodore and his team are developing a new technology that maps where these molecules are in relation to each other in three-dimensional (3D) space. The work is leading to a new spatial understanding of biological processes, such as the metabolism of our cells and the interactions between microbes in the environment, as well as offering insights into how they can go wrong. "If we want to truly understand how all these

Researchers are developing a clearer picture of the molecular environment of our skin's surface.

keen to understand these variations to gain new insights into both normal and abnormal processes in our bodies.

Molecular maps

To identify molecules in a sample, researchers usually turn to a method known as mass spectrometry, or mass spec for short. This technique involves ionising the molecules and then using electric and magnetic fields to 'weigh' each one. The machine produces patterns known as spectra, which researchers can then interpret. However, some molecules come in a range of slightly differing forms, so the spectra of samples containing many molecules can be extremely difficult to decipher. New developments in the field are providing even more information for scientists to contend with. For example, imaging mass spec not only identifies molecules but also determines their location in space. Scientists can place a thin section of a tumour or cell culture on a microscope slide and use a laser to systematically vaporise the molecules within it, point by point. They can then cross-reference the molecules they find to the points on the slide from which they originate. Putting this location information together with the mass spec data requires powerful software – software that Theodore was in an ideal position to develop thanks to his background.

Maths to mass spec

Having completed a PhD in mathematics and statistics in his home town of St Petersburg in Russia, Theodore embarked on a postdoctoral research project in Bremen, Germany, predicting bank transactions over time for a credit-card company. There, a colleague pointed out that Theodore's expertise in developing algorithms to track how things change over time could also be applied to the rapidly growing field of mass spectrometry. "For me this is the perfect field," he says. "We're working with gigabytes, even terabytes of data, and my background in

Image courtesy of EMBL Photolab/Marietta Schupp



Theodore Alexandrov

mathematics really helps."

In 2012, together with Pieter Dorrestein from University of California, San Diego, USA, Theodore came up with the idea of creating maps of metabolites on the human skin. This rapidly grew to involve more international colleagues and to map both metabolites and microbes on the skin. By combining mass spec and imaging information, the team was able to create a 3D map of the molecules clinging to the skin of two volunteers. What's more, they also correlated this map with information on the distribution of different microbial species. "What's unique about our approach is that we always try to bring spatial information into the analysis," Theodore says.

Molecules and microbes

Thanks to this spatial analysis, researchers now have a better picture of the molecular environment of our skin's surface. They also have a starting point to understand more about how this environment might affect our skin's relationship with its resident microbes. The interconnections between our cells and the trillions of microbes that inhabit our bodies are currently of intense research interest, as evidence mounts that these microbes have a profound influence on our health (see Viosca 2015 in this issue, p16-18, to read about the microbial colonies in our mouths).

processes work, then we need to see where all these molecules are," says Theodore.

The field in which Theodore's team works is known as metabolomics: the study of the biochemical fingerprints produced by the reactions in our cells. A person's metabolome is hugely complex and dynamic: doing something as innocuous as drinking a cup of coffee or eating a sandwich, for example, dramatically alters the mix of substances produced by our cells – within seconds. Different kinds of cells and tissues have different metabolomes, which can change as a result of disease or a changing environment. Researchers are

Image in the public domain



identify more of the molecules in their samples. At the moment, the fact that one molecule can generate hundreds of different signals in a mass spec machine means that scientists can only interpret a small fraction of their spectra. “I’m pretty sure we’re just scraping the surface: we’re not getting the full molecular snapshots,” says Theodore. This work forms the basis of a European project that Theodore is co-ordinating, bringing together eight partners from academia and industry. “They are all interested in really getting this working as a community effort,” he explains. But even as his team grapples with the challenges of moving mass spec into the third dimension, Theodore already has his sights set on the fourth. Being able to monitor metabolomes in time as well as space will let scientists track biological processes as they happen. “It’s still very preliminary, and we would like to improve the resolution to really understand this complexity,” he says. “But we can already see how metabolomes change over time.”

EMBL



The European Molecular Biology Laboratory (EMBL)^{w1} is one of the world’s top research institutions, dedicated to basic research in the life sciences. EMBL is international, innovative and interdisciplinary. Its employees from 60 nations have backgrounds including biology, physics, chemistry and computer science, and collaborate on research that covers the full spectrum of molecular biology. EMBL is a member of EIROforum^{w2}, the publisher of *Science in School*. See the list of all EMBL-related articles in *Science in School*: www.scienceinschool.org/embl

Moving mass spec into the third dimension promises to revolutionise many areas of research. “It is now being used in clinics, biomedical research and pharmacy,” explains Theodore. One key example is cancer research. Individual tumours contain cells that differ from each other. Understanding these differences is therefore very important if we are to learn more about how the disease develops and progresses. “One cell can change everything,” says Theodore. “Now, we can see molecular differences between the cells.”

Community conquests

Since joining the European Molecular Biology Laboratory (EMBL)^{w1} in November 2014, Theodore and his team have been working on two technological projects. The first is a continuation of his collaboration with Dorrestein’s group, and involves developing bioinformatics tools to map the spatial distribution of molecules in any environment. The second project involves developing new algorithms and hardware infrastructure so that users can

Reference

Viosca, J (2015) A safari in your mouth’s microbial jungle, *Science in School*, **34**, 16–18

Web references

- w1 Get more information about EMBL: www.embl.org
- w2 EIROforum is a collaboration between eight of Europe’s largest inter-governmental scientific research organisations, which combine their resources, facilities and expertise to support European science in reaching its full potential. As part of its education and outreach activities, EIROforum publishes *Science in School*. See: www.eiroforum.org

Claire Ainsworth is a freelance science journalist based in Hampshire, UK. She usually writes about genetics and biomedicine, but did once meet a dragon. A real one. Find her on Twitter: @ClaireAinsworth



CC BY-NC-ND

Teacher on the high seas

Educator, student and Arctic explorer combined – Giulia Realdon can't think of a better job than being science teacher.

By Laura Howes

Last summer, Giulia Realdon got on a plane and travelled from her home in northern Italy to Tromsø in Norway. There, she joined scientists from around the world on an oceanographic cruise in the Arctic. For 11 days she took part in experiments, interviewed researchers and shared the highs and lows of the crew as the ship travelled as far north as Svalbard before returning to Tromsø with data and samples. "It was a once in a lifetime adventure," enthuses Giulia, who describes the scientists on board as "amazing people".

Giulia's opportunity was part of the 'Teacher at sea' programme, organised by the European Geosciences Union (EGU), the French Polar Institute (IPEV) and Eurofleets 2 EU project. It was a lucky second chance for Giulia, who had first been scheduled to take part in the programme in 2012, with a cruise to the South China Sea.

Delays, caused in part by geopolitics, forced the 2012 expedition to be rescheduled to take place during exam season. Giulia had to cancel. "So when they phoned me up to offer me this second chance I couldn't believe it," she explains excitedly, "I had to go!" That new expedition was the PREPARED cruise^{w1}, a multidisciplinary voyage co-ordinated by the Italian *Osservatorio Nazionale di Oceanografia e di Geofisica Sperimentale* (the national observatory of oceanography and experimental geophysics, OGS) to investigate and define the past and present oceanographic conditions around areas of the seabed located on the eastern side of the Fram Strait between Greenland and Svalbard, Norway.

The sceneries Giulia saw off the coastline of the Isfjorden Spitsbergen (Greenland) were breathtaking.



Giulia on board the PREPARED cruise

On board, as the ship sailed in the Arctic seas, work was carried out 24 hours a day to take advantage of the continual sunlight, but each research group worked only for two four-hour shifts per day. Giulia logged data for Eli Anne Esrdal, an oceanographer from University Centre in Svalbard, who was taking water samples to measure the salinity, temperature, density and oxygen content, but she also got to meet many of the researchers and learn about what they were studying. Giulia wrote up many of these interviews on her blog, which she kept updated (in English and Italian) during her voyage^{w2}. When asked about memorable sights, Giulia can describe the amazing views from the boat or watching minke whales swim alongside, but her most enthusiastic answer involves the science itself – watching cores of the sea floor being safely



Image courtesy of Giulia Realdon



The Hornsund fjord in the Greenland sea

brought aboard. “It was something that’s technically amazing but also with a lot of suspense – will it succeed? That needs a lot of knowledge but also a lot of luck,” says Giulia, who remembers the spontaneous applause and dancing that broke out on board when the cores were safely delivered. “The history of 20 000 years from the last glaciation to the present was in those sediment cores,” she explains.

One of the newest research areas that Giulia first encountered on the cruise was the issue of microplastics, small pieces of plastic and fibres under 5 mm in size. This topic is an unfamiliar one for students but interest is rising, explains Giulia. “The problem,” she adds, “is that the microplastics accumulate in different sea layers and enter the food chain.” The full extent of the problem is still being explored,

including where most of these plastics finally go.

With a degree in biology and a master’s in science communication as well as her teaching qualification, Giulia taught natural sciences at secondary-school level for her whole career before officially retiring. But rather than putting her feet up, Giulia is now studying for a PhD in earth science education at the University of Camerino and is also the chair of the *Scienza Under 18 Isontina*^{w3}, her local chapter of *Scienza Under 18* (Science under 18), a science communication association in Italy aimed at communicating science to young people.

Many of Giulia’s career opportunities have come, she says, from attending European events such as those organised by EIROforum members. She adds that she was amazed by how useful she found her first event, at the European Molecular Biology Laboratory in Heidelberg, Germany. “I couldn’t believe how much there was out there for teachers.” These events are useful not only for learning, she says, but also for meeting other teachers and building networks, and she encourages all of her colleagues to take advantage of these opportunities.

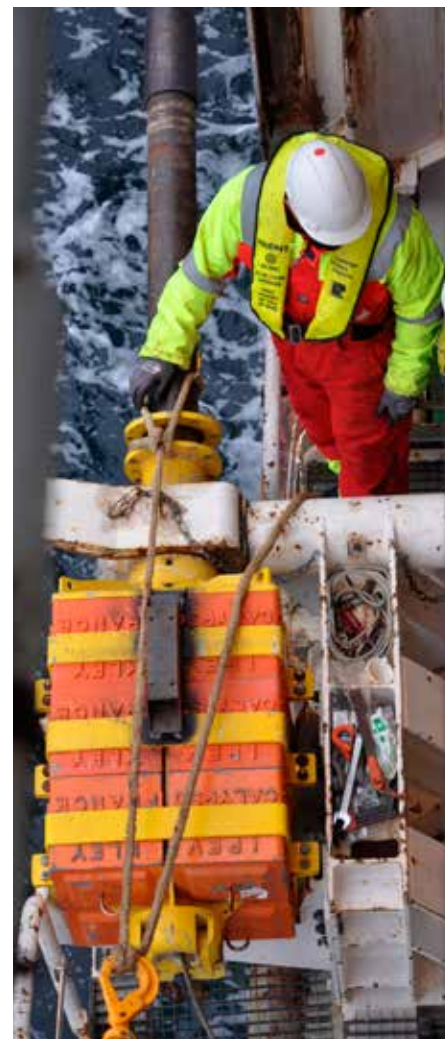

Image courtesy of Giulia Realdon

Smiles and cheers after a successful core is brought aboard



The calypso corer that took samples of the sea bed (left) required a huge machinery to be deployed (right). The cores collected were stored onboard the ship and carefully looked after by chief scientist Renata Lucchi (middle).



Images courtesy of Giulia Realdon

Indeed, it was through a European event that Giulia first heard about the Teacher at sea programme, after attending the annual EGU Geosciences Information For Teachers (GIFT) teacher workshop in Vienna, Austria. Originally a programme developed by the American National Oceanic and Atmospheric Administration, the EGU started its Teacher at sea programme in 2007.

A lasting legacy

After returning home from her adventure, Giulia worked with colleagues to develop new teaching activities and practicals to teach students more about the microplastics that she learned about on board the PREPARED cruise; some of these activities are detailed in this issue of *Science in School* (Realdon, 2015) on

p 32. She has also been inspired to talk to students about her expedition and about research in the Arctic.

Now Giulia is concentrating on finishing her PhD, although with all her other commitments she is still collecting the last of her data for her thesis on the teaching of deep (geological) time. When asked how she keeps so busy, Giulia replies immediately. "It's the privilege of being a science teacher. We are privileged because we enjoy what we do."

For her European colleagues, Giulia has a simple piece of advice to retain that enthusiasm. Sign up to European teacher workshops and get involved with the various projects, such as those run by EIROforum members. "You can learn," she concludes, "and you can share."

Reference

Realdon G (2015) Microplastics: small but deadly. *Science in School* **34**: 32-35. www.scienceinschool.org/2015/issue34/microplastics

Web references

- w1 For more information on the PREPARED expedition, visit: www.eurofleets.eu/np4/443.html
- w2 You can read Giulia's blog at: www.tasprepared.blogspot.com
- w3 For more information on *Scienza under 18 Isontina*, visit: www.scienzaunder18isontina.it/

Laura Howes is one of the editors of *Science in School*. She studied chemistry at the University of Oxford, UK, and then joined a learned society in the UK to begin working in science publishing and journalism. In 2013, Laura moved to Germany and the European Molecular Biology Laboratory to join *Science in School*.



CC BY-NC-ND

Microplastics: small but deadly

Try these activities to demonstrate the hazards of plastic waste in our oceans.

By Giulia Realdon

While sailing in the Arctic as a 'Teacher at sea' in 2014^{w1}, I first heard about the problem of microplastics – fragments of different polymers, all smaller than 5 millimetres in diameter, that are now found in nearly every environment. Worryingly, due to their small size, marine microplastics are eaten by zooplankton and so enter food chains, producing a new type of marine pollution.

Back at home, I shared my experiences with colleagues at the association *Scienza under 18 Isontina*^{w2} and together, concerned about this emerging environmental problem, we developed new teaching activities on microplastics to be presented in Italian schools during UNESCO's sustainability week in 2014. This article details these practical experiments and drama activities, suitable for students aged 3–16.

Going fishing

In this drama activity, young pupils (aged 3–7) act out the story of how microplastics find their way into our food. Full details of the activity can be downloaded from the *Science in School* website^{w3}.

Introduce the story of John and Mary, who live in a small house near the sea. They go fishing every day to find food to eat and one day, they throw lots of plastic rubbish into the sea. What happens to it? The pupils act out how the sun, wind and waves break the plastics into tiny pieces: microplastics. The pupils then pretend to be small fish that eat the microplastics, larger fish that eat the smaller fish, and a tuna fish – played by one pupil – that eats the larger fish, together with all the microplastics. To John and Mary's surprise, when they catch the tuna fish and take it home to eat, it is full of tiny pieces of plastic!

To conclude the activity, the children discuss how to avoid microplastics polluting the sea. For example:



- ✓ Biology
- ✓ Chemistry
- ✓ Ecology
- ✓ Organic chemistry
- ✓ Ages 3-16

REVIEW

The article describes several activities to introduce students to microplastics, tiny plastic particles, and their impact on the marine environment.

One is a drama activity for very young pupils about how microplastics find their way into the food chain. Role-playing can help children to better understand the processes that these plastics are involved in and why they are so dangerous. Other practical activities described in the article involve materials (e.g. sand, cosmetics, personal-care products, bottles, and plastic bags) that students are familiar with, which can help to raise interest in microplastics and the effect they can have in ecosystems. All the materials required for the experiments are readily available and the instructions are easy to follow, making the activities suitable for students to perform in small groups.

Finally, the text could be used as a starting point for discussing the consequences that the consumption of certain products can have on our environment. The discussion can help students to be aware that simple actions can make our lives greener and reduce our impact on the planet.

Mireia Güell, Spain

- Do you like eating fish? If so, what is your favourite fish to eat?
- What happened to the plastic objects that John and Mary that threw away – how did they turn into the small bits of plastic that the fish ate?
- Should we eat fish? What are the benefits and disadvantages?
- People do not normally throw their rubbish directly into the sea. So how does so much plastic end up in the sea?
- How should we dispose of plastic objects in a better way? (Show the pupils a bin for collecting plastic waste separately. Explain that many plastics can be recycled.)

Exploring plastics

This is a practical activity for students aged 8–16 that investigates the characteristics and uses of different household plastics. The class works in small groups of 2–4 students.

Materials

For the whole class:

- 0.5 l acetone
- Small polystyrene block (about 10 cm x 15 cm x 5 cm)
- Hairdryer
- 1 l of diluted rubbing alcohol (40% rubbing alcohol by volume)

For each student group (or in the case of younger children, for the whole class):

- Bag of common plastic household objects (e.g. bottles, cups, trays, cutlery, boxes, bags)
- Two sets of plastic strips, each consisting of strips of polypropylene (PP), polyvinylchloride (PVC), high density polyethylene (HDPE) and polystyrene (PS), marked with their name using a permanent marker. The strips can be cut from household objects (bottles, cups, trays and other containers); you will normally find the composition of each object on its label.
- Four glass beakers or small jars with lids (100 ml) marked with the names of the plastics (PP, PVC, HDPE and PS)



Investigating the effect of heat on different plastics

- Worksheet created by the teacher, listing the name, abbreviation and recycling symbol of the four different plastics
- One 500 ml rectangular plastic tub
- One spoon
- Tap water
- Salt
- Absorbent kitchen paper (paper towels)

Procedure

The uses of different plastics

Ask the students to take the bag of plastic objects, and for each item:

- Identify its use.
- Find the abbreviation/symbol of the plastic type (this should be marked on the object).

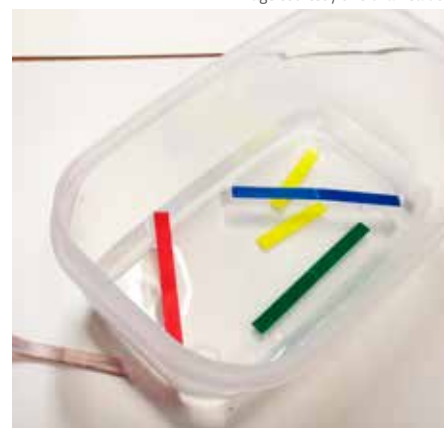

Investigating the buoyancy of different plastics

- Match this to the information on the worksheet to identify the type of plastic.

Then ask the students to discuss what types of object each plastic is used to make. For example, yoghurt pots are normally made from from PVC, carrier bags from HDPE and food boxes from PP.

The characteristics of different plastics

Give each group of students two sets of plastic strips, and ask them to carry out the following investigations.

Safety note: The first experiment should be carried out in a fume cupboard or, if this is not possible, close to an open window. See also the general safety note on the *Science in School* website.

1. Action of acetone. This takes at least 30 minutes, so begin with this test.



Small fish 'eating' microplastics.

Image courtesy of Marta Cucut

Take the first set of plastic strips and put each strip into a separate beaker. Half fill the beakers with acetone and put the lids on. At the end of the activity, observe which plastics have been affected by acetone. (Only PS will be affected, becoming softer.)

2. Density. Put the four strips into the plastic tub half-filled with the diluted alcohol solution (less dense than water). Press them down and observe if they float or sink. Then empty the tub, wipe the strips, and half fill the tub with tap water. Again, see if the four strips float or sink. Finally, add a spoonful of salt to the water, stir until it dissolves, and again test if the four strips float or sink.

The students will see that the plastics have different densities; some are denser than water and some less dense. PP has a density of 0.90 g/cm³, HDPE of 0.95 g/cm³, PS of 1.04 g/cm³ and PVC of 1.40 g/cm³.

3. Action of heat. Insert the four strips into the polystyrene block so that they stay vertical. Aim the jet of the hairdryer at the strips (the teacher should carry out this step for younger students) and observe if they bend or not.
4. Flexibility and fold colour. Take each plastic strip and fold it forwards and backwards to observe its flexibility. Then fold the strip over completely, pressing it down, and observe the colour of the fold (unchanged or white).

After the experiment, discuss the students' observations. Ask the students which type of plastic would be most suitable for the following uses, and why?

- Acetone bottles
- Sea buoys
- Lake buoys
- Coffee cups
- Objects that are repeatedly bent, e.g. shampoo bottles with flip-up lids

Microplastics on the seashore

In this activity, students aged 11–16 investigate the microplastic pollutants in



Anyone for a plate of fish (and plastic)?

a sample of sand from a local seashore, lakeside or river bank.

Materials

- A sample of sand polluted with plastic and other waste. (Nearly every European sandy beach contains microplastics, along with plastic fragments of different sizes.)
- Magnifying lenses

Procedure

1. Ask the students to observe the sand samples with the naked eye and with the magnifying lens. Can they see any plastic fragments?
2. Discuss where the students think the fragments come from.

3. Watch some videos about plastics in the environment^{w4}
4. Discuss with the students the hazards of microplastics and the importance of preventing marine pollution by separately collecting, recycling and re-using plastic objects.

Microbeads from cosmetics

Microbeads are another source of microplastics. These tiny plastic beads are used in cosmetics and personal care products (e.g. exfoliating and hand-washing creams, toothpastes). In this activity, students (aged 11–16) isolate and examine microbeads from such products, and consider their impact on the environment.

Image courtesy of Giulia Realdon



Cosmetics and personal care products often contain microplastics

Materials

- Some cosmetics and personal care products containing microbeads. Check the composition: if polyethylene is listed, the product contains microbeads.
- Clear acetate sheets
- Magnifying glasses or a microscope
- Transparent plastic cups
- Tap water
- Dishwashing detergent
- Salt
- Spoon

Procedure

Using the materials above, ask the students to:

1. Read the composition of the product to confirm that it contains microbeads.
2. Examine the product by spreading it on an acetate sheet and looking at it with the magnifying lens (or a microscope), and also by touching it.
3. Test the microbeads for buoyancy in three different liquids, using the transparent cups:
 - Tap water
 - Water plus detergent (1/2 spoonful per cup)
 - Water plus salt (1 spoonful per cup).
4. Based on the students' results, predict whether in the natural environment, microbeads will float or sink in freshwater (e.g. in a lake) and in saltwater (e.g. in the sea).

How many microbeads are we dumping in the sea?

This extension to the previous activity asks students aged 11–16 to make a rough estimate of how many microbeads are being dumped each year by people in their town, and to investigate and debate the environmental issues involved.

Materials

- As for the previous activity, plus:
- Measuring spoons with a volume of

5 ml (like those used for cough syrups, etc.)

- Coffee filters

Procedure

Ask the students to:

1. Measure 5 ml of a product containing microbeads and dissolve it in a cup half-filled with tap water plus 5 ml of dishwashing detergent.
2. Stir the mixture for one minute, then filter the mixture with a coffee filter.
3. Transfer the microbeads from the filter paper to an acetate sheet. Now count the microbeads.
4. Using this result and the volume of the product's original container, calculate how many microbeads are contained in a whole tube or bottle.
5. Estimate how many containers of this product are used by a person in one year, and how many people in their town are likely to use this product.
6. Multiply these numbers together to calculate how many microbeads their town is dumping into the sewage system (and then into the sea) per year from this one product.

Finally, ask the students to research information about the problem of microbeads in the environment, and on current debates and actions limiting or banning their use in products^{w5}.

Acknowledgements

The activities described in this article were developed jointly by the author, Giuliana Candussio, Marinella Manià and Serenella Palamin. All four are members of *Scienza under 18 Isontina*^{w2}, an association that aims to inspire school students and teachers and to share good practice.

The 'Exploring plastics' activity was adapted from materials developed as part of *progetto APQUA*, the Italian version of the Lawrence Hall of Science, University of California at Berkeley's Science Education for Public Understanding Program (SEPUP). The *progetto APQUA* materials were kindly provided by Federchimica-Assoplast, the association of Italian plastic manufacturers.

Web references

- w1 The author, Giulia Realdon, recorded her experiences as a 'Teacher at sea' in a blog. See: www.tasprepared.blogspot.com

w2 To learn more about the *Scienza under 18 Isontina*, visit the association's website (in Italian). See: www.scienzaunder18isontina.it

w3 Full details of the drama activity about fishing can be downloaded from the *Science in School* website. See: www.scienceinschool.org/2015/issue34/microplastics

w4 To learn more about plastics in the oceanic environment, see the video 'It's a plastic world' (<http://itsaplasticworld.com>) and a thought-provoking video about marine litter and plankton (www.youtube.com/watch?v=xzklQprO59g)

w5 To learn more about microbeads in personal care products, see the 5Gyres website: www.5gyres.org/microbeads

w6 To learn more about SEPUP, visit the programme website. See: <http://sepuplhs.org/middle/modules/living>

Resources

Thompson RC et al (2004) Lost at sea: where is all the plastic? *Science* **304**: 838. doi: 10.1126/science.1094559

Lusher AL, McHugh M, Thompson RC (2013) Occurrence of microplastics in the gastrointestinal tract of pelagic and demersal fish from the English Channel. *Marine Pollution Bulletin* **67**(1): 94–99. doi: 10.1016/j.marpolbul.2012.11.028

Watch a fun video (in Italian) on what it might be like to live without plastics and other synthetic materials: See: www.sperimentarea.tv/ondemand/vivere-senza-chimica

Further useful information can be found in the abstracts of a 2014 conference entitled 'Fate and impact of microplastics in marine ecosystems'. See: <http://micro2014.sciencesconf.org> or use the direct link: <http://tinyurl.com/microplasticsfate>

To find out more about the author, Giulia Realdon, see an interview in this issue of *Science in School*:
Howes L (2015) Teacher on the high seas. *Science in School* **35**: 29–31. www.scienceinschool.org/2015/issue34/realdon

Giulia Realdon studied biology and science communication at the University of Padova, Italy, and has taught science for many years. Now retired from school teaching, she is studying for a PhD in earth science education at the University of Camerino, Italy. She also organises science communication events for schools for the association *Scienza under 18 Isontina*, writes about science education (in Pearson Italy's *Science Magazine: La scienza in classe*) and is a long-standing reviewer for *Science in School*.



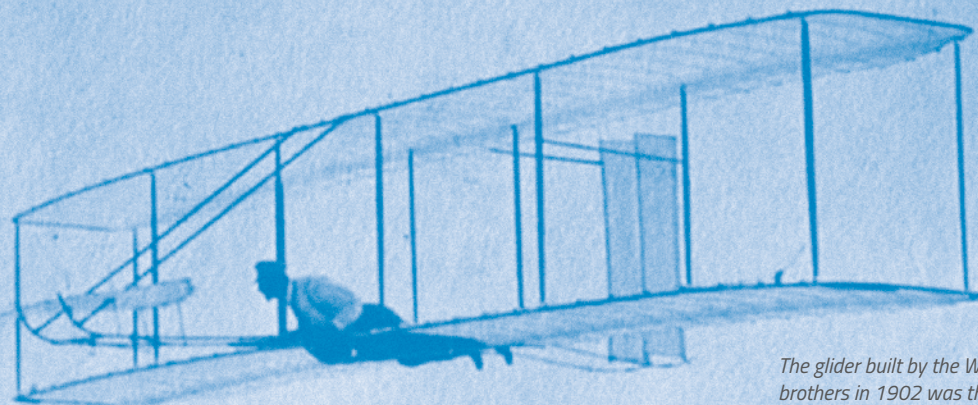

The glider built by the Wright brothers in 1902 was the first flying machine able to change direction in a controlled way.

High flyers: thinking like an engineer

Designing a glider wing helps students understand forces and what it means to be an engineer.

By Bridget Holligan

Mary and Michael have good ideas but struggle to implement them: they need the help of your class to fly a glider in a straight line between their two bedroom windows.

For approximately three and a half hours, small groups of pupils (aged 9–12) will work together to explore the forces that allow heavy machines such as gliders to fly, to investigate appropriate materials, and then to design and test their own gliders.

The 'high flyers' design challenge

Materials

- Glue
- Masking tape
- Paper clips
- Modelling clay
- String
- Scissors
- Measuring tape
- Rope suitable for a tug-of-war

For the launcher:

- Thick cardboard
- Elastic



REVIEW

- ✓ Physics
- ✓ Engineering and material science
- ✓ Ages 11–16

Engineering challenges provide a wide variety of learning opportunities. This activity allows students to act as engineers by working as a team to solve problems in addition to applying their knowledge of forces and material science. Students often fear making mistakes but the nature of the challenge demonstrates how trial and improvement is a crucial part of the science and engineering process. The challenge would be particularly suitable for science or engineering days.

The activity could also lead to wider discussions on topics such as “What do you think are the similarities and differences between this challenge and engineering projects in industry?” and “What are the advantages of gliders over powered aircraft?”.

Jeremy Carter, Bradfield High School, UK

Email from Mary

From: michaelandmary@monotreme.co.uk
 To: Pegasusyr5
 Subject: Please help us!
 Attached: Picture of our street.jpg

Dear Year 5,
 Please help us!

Your head teacher suggested that you would be the best people to help us with a problem that we need to solve.

My name is Mary and my bedroom window is opposite my best friend Michael's window. We think it would be fun to build a model glider that can be flown from my window to Michael's window (and for him to be able to send it back to me). That way we can send each other messages and, if we can build the glider well enough, perhaps small gifts.

Can you help us by finding out about gliders and sending us some information on how to build a glider that works? I've attached a picture showing you our houses, which might help.

Thanks for all your help,
 Mary

Image courtesy of Science Oxford

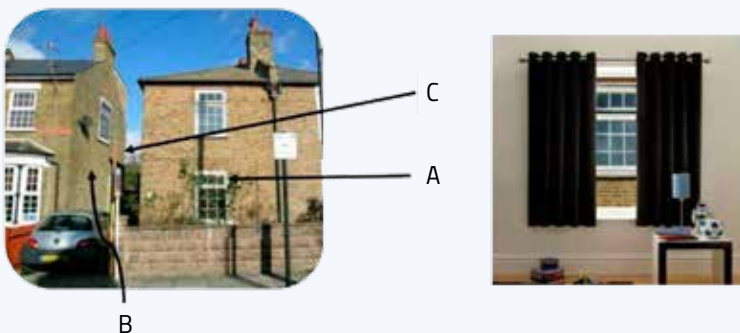

Pictures showing my house and Michael's house (left): A – my house, B – Michael's house, C – The distance between our houses is 3m. Michael's window is exactly opposite mine and is the same size (1 m x 1 m).

For the glider:

- Standard fuselage template^{w1}
- Straws, e.g. art straws or drinking straws
- Lolly sticks
- Tightly rolled paper – either normal writing paper or newspaper
- Tracing paper
- Newspaper

- Thin plastic bags
- Thin cloth

Supporting information, images and instructions can be downloaded from the *Science in School* website^{w1}.

Procedure

Before the lesson, the teacher should:

- Build one or more launchers (see

online instructions^{w1}) to test the gliders.

- Prepare as many fuselages as necessary for the whole class (see online instructions^{w1}).
 - Set up a couple of test areas on the floor, using masking tape to mark a launch line and a 3 m perpendicular line.
1. Set the context of the challenge by giving Mary's email to the pupils, together with the photo of the friends' houses (see box). Their bedroom windows (1 m x 1 m) face each other, 3 m apart. This automatically sets up the design specifications for the problem: the pupils need to build a glider that will fly a distance of at least 3 m, between two points at the same height.
 2. Discuss the key specifications of the challenge. For five minutes, small groups of pupils should list what their glider has to do to meet the challenge set by Mary and Michael (i.e. distance of flight, path line, and weight to carry). They should also realise that the glider must be made of everyday materials so that Michael and Mary can reproduce it.
 3. Discuss the specifics of gliders. Show your pupils images of planes and gliders^{w1} and ask them to discuss for five minutes what the differences between gliders and planes are, and how they think gliders take off. Show them a Youtube video^{w2} of a glider launch.



Image in the public domain. Image source: Wikimedia

Images courtesy of Science Oxford

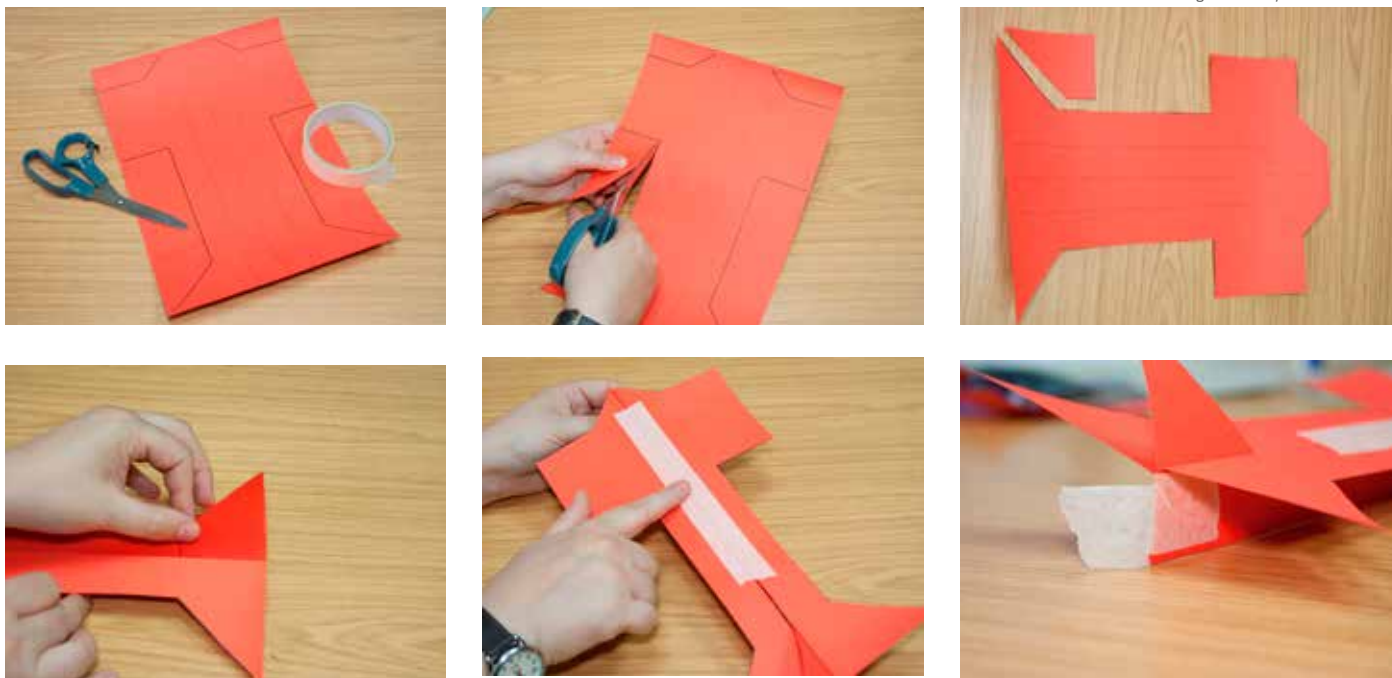

The online instructions will give you all the details to build the glider's fuselage.

Image courtesy of Science Oxford

Worksheet 1 Lesson 1- Glider parts

Name of Engineer: _____

Date: _____

Match the parts of a glider to the correct descriptions.

Descriptions	Glider parts
An area where a pilot can sit with a clear cover that allows them to see outside the glider.	Wing
The central part of the glider.	Tail
Helps the glider to fly straight and level, with a rudder that helps the glider to steer.	Cockpit
Creates a force called lift that keeps the plane in the air.	Fuselage

Label the different parts of the glider below

Image courtesy of Science Oxford

You can use a similar worksheet to discuss the importance of the different parts of the glider.

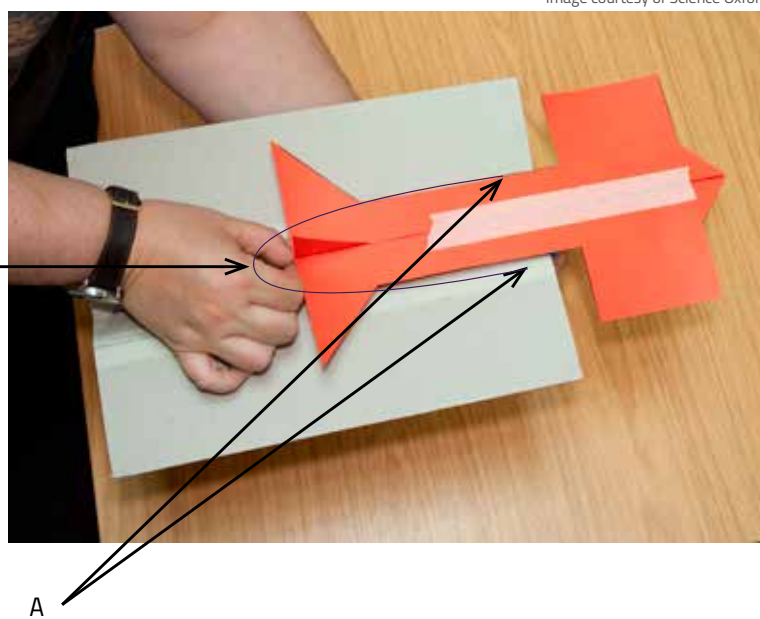

Demonstration of how to use the launcher: A - Attach the elastic here, B - Elastic stretched round back of fuselage

- Lead a five-minute discussion on the different parts of a glider (e.g. cockpit, fuselage, wings and tail) and the role played by each part^{w1}.
- Explore the forces involved in flight with the following activities (about 20 minutes each):
 - Use the rope to stage a mock tug-of-war to illustrate the equilibrium of forces needed to keep the rope

- static. Pupils should understand that the rope moves in the direction of the greatest force, and that forces of equal magnitude acting in opposite directions to each other balance each other out.
- Using a paper plane, discuss the influence of gravity (what happens when you release the plane without throwing it?) and of lift and weight forces (what do we

- call the upward force that helps a glider to fly? What do I need to do to make the glider fly through the air?).
- Explore the material properties of wings. After studying pictures of old planes, discuss the most important characteristics of wings: the frame needs to be both light and rigid, while the cover should be as light as possible.

Images courtesy of Science Oxford

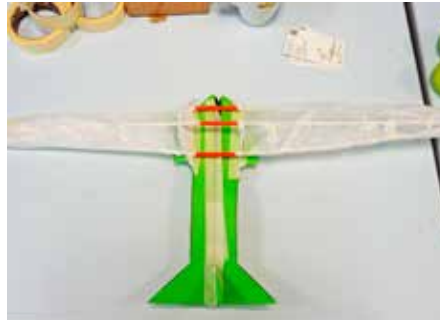
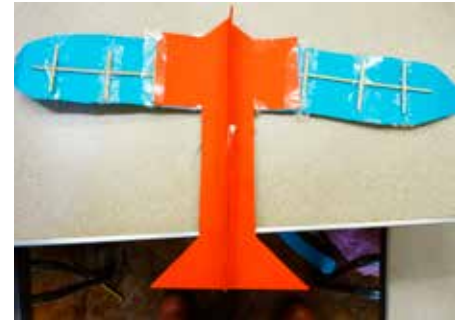
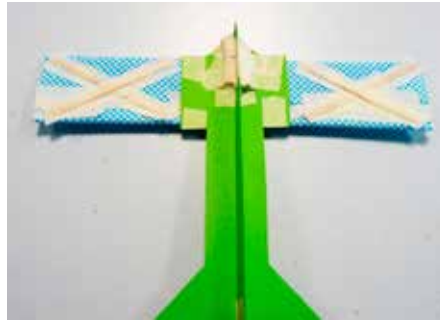

Pupils can be very creative when building glider wings and come up with different models.

7. Explore how you can modify the rigidity of materials, such as paper: take five sheets of paper, leave the first one intact and fold the others to make a triangle, a tube, a W shape, and a shape of your liking. Then, carry out two brief experiments^{w1}:
 - a) Place the folded paper shapes on a table and slowly push them towards the edge so that more than half of each shape sticks over the edge (you may need to hold the other end to stop it falling). Pupils will observe that some shapes will not bend because they are stiffer, although they are made with the same material.
 - b) Move the folded paper shapes onto the table. Do they stand up on their own? What happens if you press down on them gently?
8. Select the best materials: on the basis of the previous steps, ask your pupils to determine which materials would be good for building the wing's frame, covering it, and for fastening things together. Remind pupils that some materials can be made stronger just by changing their shape, so, for example, paper may be suitable for the wing frame as well as the wing covering.
9. Start building! This takes around 30 minutes.
 - a) Give each group of pupils a fuselage.
 - b) Using the materials they selected, the pupils should draw a labelled plan of their wings.
 - c) Pupils should then build their wings and attach them to the card fuselage.
10. Test and improve the glider; this should take approximately 60 minutes.
 - a) Bring the launchers to the test areas you have prepared in advance, and demonstrate the launching process to your pupils.
 - b) Pupils should test whether their

The forces in glider flight

Scientists and engineers refer to the downward force that is produced by gravity as weight, w . How much weight force there is on an object depends on the acceleration due to gravity, g , and mass, m . Mass is how much 'stuff' there is in an object and it is measured in grams (or kilograms, kg). In English, we often use the word 'weight' when we are really talking about 'mass'. If you want to make something fly, like a glider, you want to make it as light as possible so that the downward weight force can be kept as small as possible. Weight, mass and gravity are linked together by the following equation:

$$w = m \times g$$

This is an important principle for an aeronautic engineer.

Scientists and engineers call any force that works upwards 'lift'. Wings only help to lift a glider into the air if the glider is moving forward fast enough, because it is the movement of air over and under an aircraft's wings that is essential to creating lift. If you want a glider to fly in a straight line, you need the forces of weight and lift to be carefully balanced, just like in the tug-of-war demonstration.

Image in the public domain. Image source: Wikimedia



Gliders need to be towed in the air, usually by being attached behind a plane, before they can fly on their own. This photo of a glider was taken from the towing plane and shows the rope linking them.

design meets the specifications defined in step 2. It does not need to be perfect: very few ideas work perfectly the first time, and working out what to improve is how engineers learn.

- c) Pupils should observe the flaws in their initial model, and reflect on the causes and on how to correct them. After modifying their wings, they should re-test them. Common issues (e.g. the glider not balancing properly or being too heavy) and their solutions are addressed online^{w1}.

Web references

w1 The 'high flyers' lesson plan was developed by Science Oxford within the EU 'Engineer' project, which developed ten design challenges set in a wide range of pupil-friendly engineering contexts that also link with school curricula for science, design and technology. It can be downloaded from the *Science in School* website (www.scienceinschool.org/2015/issue34/engineer) and the Science Oxford website (www.scienceoxford.com/schools/schools/engineer-resources).

The lesson plan contains additional information for the glider activity:

- The worksheet on page 49 includes a standard fuselage template.
- Appendix 5 describes how to build the launcher.
- Appendix 3 contains images of aeroplanes and gliders.
- The worksheet on page 44 describes the different parts of a glider and their roles.
- The worksheet on page 46 describes two experiments to investigate the rigidity of materials.
- Pages 26–27 cover common problems when building your glider and offer some solutions.

w2 Watch a video showing how gliders can be launched. See: www.youtube.com/watch?v=BHms8MVHm5I

Resources

Aeroplanes are different from gliders because they have an engine, but their general shape and structure are similar. This NASA resource explains how planes fly: <http://1.usa.gov/1kP4WRp>

The Phenomenal Physics website also gives a good explanation of the physics of flight. See: www.portageinc.com/community/pp/flight.aspx



Bridget Holligan has worked in the informal science learning and public engagement sector for more than 20 years, following a BSc in Chemistry and an MSc in Science Communication. After three years at the Exploratory Science Centre in Bristol, UK, she moved to Science Oxford where she is now Director of Education and Engagement. From 2011 to 2014, Science Oxford was the UK partner for the EU-funded ENGINEER project, which aimed to improve primary-school pupils' understanding of the engineering design process by providing practical resources and teacher training.



CC BY-NC-SA



Image courtesy of Taro Taylor; image source: Flickr

You can make your own volcano model in the classroom

Experimenting with storytelling

Folktales can be a great way to introduce hands-on science into the primary-school classroom.

By Sai Pathmanathan

Earlier this year, I ran workshops for young children (aged 7–10) and their parents to do hands-on practical activities linked to a cultural story or folktale. In many UK primary schools there are pupils from many different backgrounds, with as many as 25 native languages being spoken at some schools. Despite their differences though, everyone enjoys a good story. Not only did some of these stories resonate with people from different cultures, they also promoted good values and contained some science.

Although these activities were originally developed for children and their parents, they use cheap, easily accessible equipment and can be repeated effortlessly in the classroom. Here, I describe activities that present very different aspects of science, all of which can be introduced with a folktale.

Making butter: the two frogs

The first activity, making butter, is based on a Russian folktale.

Once upon a time, there was a big frog and a little frog. One day they went on a journey and found themselves on a dairy farm. While hopping around, they accidentally hopped into a huge bucket filled with cream. The sides of the bucket were too high and slippery for them to climb out.

The little frog said that they needed to keep paddling until someone came to rescue them, but the big frog said he was too tired to swim and he slowly began to sink. The little frog urged the big frog to keep paddling and as they paddled, the cream started to turn into butter. Soon there was a huge lump of butter floating on the surface. The frogs climbed onto it, and were able to hop out of the bucket and all the way home.

Materials

Per participant:

- Disposable plastic shot glass, or other small transparent container with a narrow opening
- Plastic spoon
- Kitchen foil (10 cm x 10 cm)
- Small balloon

Per class:

- Scissors
- 300–600 ml full-fat double cream (minimum 48% milk fat)
- Optional: crackers or bread (edible activities are always memorable!)

Procedure

1. Cut the neck off the balloon.
2. Pour about 1 cm of cream into the container (the more you use, the longer the experiment will take).
3. Place the foil over the mouth of the container, and stretch the balloon top over the top to prevent leaks.
4. Now shake! It should take no more than 15 minutes to turn the cream into butter. Within 5 minutes, you should see the thickness and colour begin to change: from thin cream to thicker cream, then to a yellow solid. You will hear and feel a rattling as a small ball of butter forms.
5. Remove the balloon and the foil. There should be a lump of butter floating in white, runny buttermilk.
6. Optional: using the plastic spoon, spread a small amount of the butter on a cracker or piece of bread to taste. (Please check your local regulations to see if this is allowed.)

What is happening?

Cream is an emulsion: tiny droplets (in this case, of fat) suspended in another liquid (mostly water, but also proteins, sugars and minerals such as calcium). The process of shaking the cream (churning) makes the droplets bang together. If they hit each other with enough force, they stick to each other.



REVIEW

- ✓ All sciences
- ✓ Ages 12 and under

The article is interesting and novel in that it helps the teacher to teach science in an interdisciplinary way. As a teacher, I would love to implement such activities in my science lessons as they are a great way to link science with language lessons, and specifically storytelling. The experiments are really interesting for primary-school pupils and are a little out of the ordinary for such young children.

Christiana Th Nicolaou, Centre of Educational Research and Evaluation, Ministry of Education and Culture, Cyprus

Images courtesy of Sai Pathmanathan



You can even taste the results of your experiment

Image courtesy of Sai Pathmanathan

The lump gets bigger as each additional droplet attaches.

You could ask your pupils, for example:

- Where does cream come from?
- What does cream contain? How does it differ from milk?
- Do you think it is necessary to use double cream in the experiment? Could you use single cream or even milk? Why / why not?
- If the fat is now mostly in the butter, what is left in the buttermilk?

The moral of the story also fits well with the activity. Like the frogs, the children need to work hard and not give up!

Erupting volcanoes: Pele, the volcano goddess of fire

Based on a Hawaiian legend, this activity models the action of volcanoes.

One day, the sea goddess Namaka was angry with her sister Pele, the goddess of fire. So their parents, Mother Earth and Father Sky, sent Pele and her other brothers and sisters off in a canoe to find a safe place to hide from Namaka. They landed on an island and Pele began to build a home for them, using her digging stick to make a pit in which she then lit a fire. The fire rose up out of the earth, sending rivers of hot lava into the ocean and pushing the water away. As the lava cooled, it turned to stone, forming the island of Kaua'i: a new home for Pele and her siblings.

Namaka was still angry though, and sent huge waves to flood the pit and put out the fire, so Pele and her siblings had to move again. They found a new island and once again, Pele dug a pit and lit a fire; the resulting lava created the island of O'ahu. Again, Namaka sent the waves to flood Pele's new home. Finally, the siblings arrived on the Big Island, which was too high for Namaka's waves to drown the fire. Native Hawaiians believe that Pele is still living in the Kilauea crater on the Big Island.



Making a volcano

Materials

Per participant:

- Small block of modelling clay
- Pencil
- Bowl
- Plastic spoon

To share:

- Bicarbonate of soda (NaHCO_3)
- Vinegar (CH_3COOH)
- Optional: glitter or sequins (to make the lava sparkle)
- Optional: plastic cups, 3 ml plastic pipettes (to share out vinegar)

Procedure

1. Mould the modelling clay into a mountain shape. This is your volcano.
2. Using the blunt end of a pencil, make a small hole in the top, just deep enough to hold some lava mixture.

3. Place your volcano in the bowl to prevent any spills when the volcano 'erupts'.
4. Optional: mix some bicarbonate of soda with glitter or sequins, if you want the lava to sparkle.
5. Put a small amount of bicarbonate of soda (with or without sparkle) into the hole in the volcano.
6. To make the volcano erupt, gently pour (or use a plastic pipette to add) a small amount of vinegar into the top of the volcano.

What is happening?

A volcano is an opening in Earth's crust through which molten rock (*magma*), gas and ash erupt with a lot of force. The gases that come out of volcanoes are mainly water vapour and carbon dioxide, but there are other, dangerous gases too.

The lava mixture in the activity is mainly bicarbonate of soda, an alkali. When

an acid such as vinegar reacts with the bicarbonate of soda, bubbles of carbon dioxide gas are released.

Suitable questions to ask your pupils might include:

- What is forcing the mixture out of the hole in your volcano?
- What do you think the bubbles consist of? What other gases can you name?
- Is the mixture hot? Why / why not?
- How does what is happening to your model volcano compare with the action of a real volcano?

You could pass around some lava rock (e.g. a pumice stone), which is surprisingly light. Or you could introduce the Hawaiian words for different types of lava: *Pahoehoe* is smooth lava that cools slowly and moves slowly, and *A'a* is sharp lava that cools quickly and moves fast.

Displacement of water: the crow and the pitcher

Based on Aesop's fable of the crow and the pitcher, this activity investigates the displacement of water.

There was once a very clever crow. One hot day, he was thirsty and after flying around for a long time searching for water, he came across a pitcher [a large jug] of water, but it was nearly empty. He couldn't reach the



In Aesop's fable, the clever crow used stones to raise the level of water in the jug.

Image courtesy of Sai Pathmanathan



Using the crow's trick to raise the water level

water, however hard he tried, and if he tipped the pitcher over, the water would sink into the ground before he could drink it. The crow thought for a moment, then took a pebble and dropped it into the pitcher. He noticed that the water moved upwards. The more stones he dropped into the pitcher, the more the water moved upwards. Soon he was able to have a refreshing drink of water.

Materials

Per participant:

- Transparent disposable cup
- Marker pen
- Water

To share:

- A selection of small objects, e.g. pieces of ice, pebbles, shells and modelling clay

Procedure

1. Half fill the cup with water, then use the marker pen to draw a line showing the water level.
2. One at a time, drop a variety of objects into the cup, and see what happens to the level of the water.

What is happening?

Because water cannot be compressed, it moves up (i.e. is displaced) by the same

volume as that of the object added. This phenomenon can be used to determine the volume of an irregular object and thus, if we also measure the weight of the object, its density.

Volume and density may be challenging concepts for younger children, but the pupils can investigate which objects float and sink, and watch how the water level rises. Suitable questions to ask your pupils might include:

- What makes the water level rise?
- Do large objects make the water level rise more than smaller objects?
- What about hollow objects such as shells?
- Take two similar-sized pieces of modelling clay and mould them into different shapes (e.g. a ball and a worm). Does the shape affect how much the water level rises?
- What effect do objects that float (e.g. ice) have on the water level?

Older children could try to find ways to measure the volume of the different objects.

Acknowledgement

These activities were developed with the support of the UK's Biochemical Society^{w1}.

Web reference

- w1 The UK's Biochemical Society offers grants that support scientific outreach activities to communicate the excitement of molecular bioscience to young people and the community. See: www.biochemistry.org/Grants/ScientificOutreachGrants.aspx

Sai Pathmanathan is a freelance science education consultant who writes and develops creative educational resources and outreach workshops. She has previously worked as a research fellow at Queen Mary, University of London, UK; an international informal science education fellow at the National Science Foundation, USA; and director of *Ignition**, a UK-based programme of creative approaches to the learning and teaching of STEM subjects.



CC BY-NC-SA



Image courtesy of Anand Singh and Tim Saunders

Doing is understanding: science fun in India

School children in India built their own digital microscope, bent light and investigated gas laws. Find out how.

By Anand Pratap Singh, Anuradha Gupta, Ranjit Gulvady,
Amit Mhamane and Timothy Edward Saunders

In India, as in many countries, the main focus in science classrooms is on exams rather than musing on the fascinating concepts and understanding of the world that science offers. This can mean that students lose interest in studying science – a problem that is further hampered where there is a lack of facilities, expertise or mentors. We started the ‘Science is fun’ outreach programme to address these problems. The 15-person team, led by undergraduate and research scientists,

conducted four workshops with underprivileged children in Indian primary and secondary schools during December 2014 and January 2015.

The workshops explored basic science concepts, reinforced by hands-on experiments using readily available materials. They were generally successful, with students keen to participate and motivated to learn more after the workshops. We were also pleasantly surprised to see students engaging

with new concepts and not hesitating to participate in the discussions. We tried to ensure teachers were central to the activities, and also designed the experiments to be easily repeatable so that teachers could incorporate them into their own lessons once the workshops were over.

In this article, we describe three of our successful activities: building a periscope and a digital microscope, and two experiments based on the physical gas laws. All are cheap and easy to perform, yet reveal interesting scientific principles. Each activity takes about an hour.

Periscopes and the reflection of light

Periscopes allow us to look over or around obstacles without being in the line of sight, and they are still used today in submarines. The most basic version involves two plane mirrors, one placed at each end of a long tube, with the mirrors parallel to each other and at 45° to the length of the tube.

This simple periscope is easy to build in around one hour and requires no more materials than cardboard, mirrors, scissors and sticky tape. It can be used with younger children who can safely handle scissors and mirrors (e.g. 8–13),



Students using the simple periscope

as a fun activity and an introduction to the reflection of light. Older students (e.g. 14–16) could use it to learn about the reflection of plane mirrors. Figure 1 shows how the periscope is made and full assembly instructions can be downloaded from the *Science in School* website^{w1}.

Although the basic design of the periscope is simple and straightforward, it demonstrates the law of reflection: the

angle of incidence of a light ray is equal to its angle of reflection (figure 1). Since the angles of incidence and reflection are the same, light that is travelling horizontally to hit a mirror orientated at 45° will then travel vertically. By adding another mirror angled at 45° , the light path is re-orientated to travel horizontally again, but now it is displaced from the original beam path by the height of the periscope.

Figure 1: A periscope can be simply built from a piece of cardboard and two mirrors. a) Cut two holes in the cardboard. b) Fold the cardboard and tape it closed. c) Cut slits for the mirrors. d) Insert the mirrors and your periscope is ready to use.

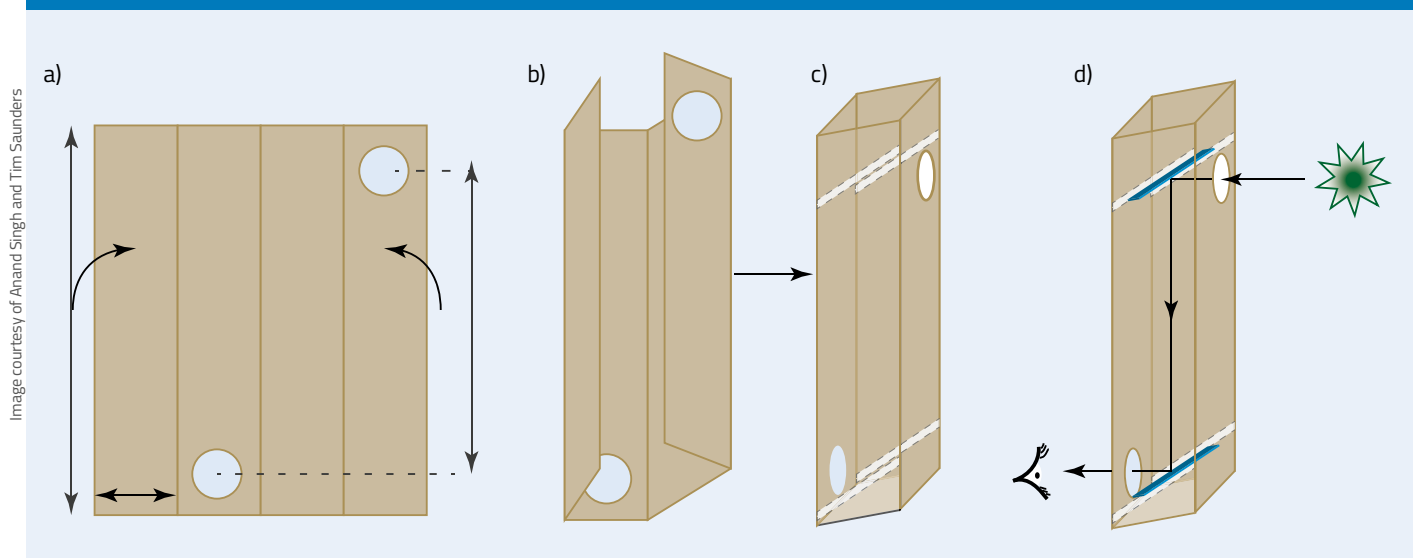

By building their own periscope, students can see for themselves that light travels in straight lines and that the direction of travel can be altered by reflective surfaces: a common use of periscopes in optics is to change the height of a light path. This activity can be extended to be more challenging for older students by requiring a different angle of observation^{w2}.

Suitable questions for your students could include:

- Periscopes have been used extensively in warfare. What examples can you think of and what are the advantages and disadvantages of periscopes for the military?

Periscopes are / were used in submarines, tanks and in trench warfare. Although they allow the viewer to make observations from a position of safety, they are only two-dimensional in that they cannot look up or down without additional components.

- What role does science have in military conflicts? Should scientists work to develop better equipment for the military?

See also Essex & Howes (2014) for a discussion of the chemical legacy of war.

- To use a submarine periscope, the viewer turns the whole periscope around, walking around the main tube. This requires a lot of space – which is limited inside submarines. Why, then, do the periscopes not simply rotate at the top?
- How would you adapt a periscope to be able to look up and down?

Building and using a digital microscope

Microscopes allow us to explore details that are too small to be seen by the naked eye, but they are usually expensive. Here, we show how to build a cheap webcam-based microscope, so that students can learn the basics of optics and image formation while exploring the microscopic world around us.

Figure 2: The reflection of light. A: observer's eye; B: object; C: mirror; θ_i : incident angle; θ_r : reflected angle

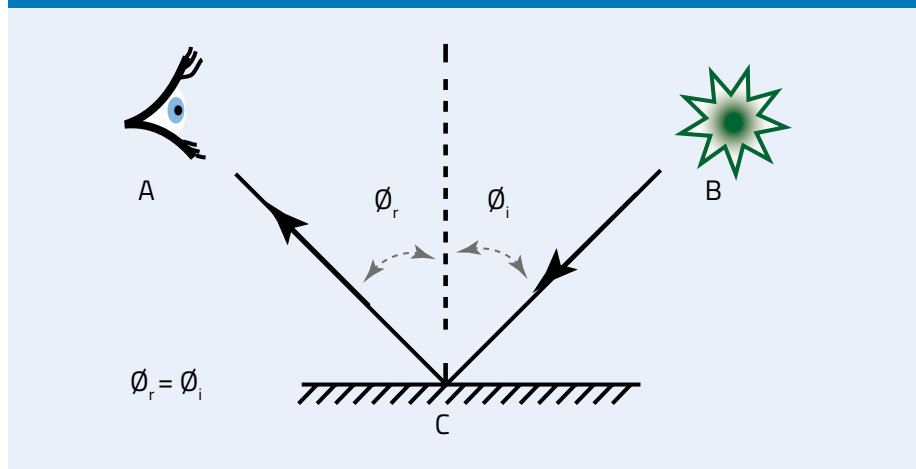
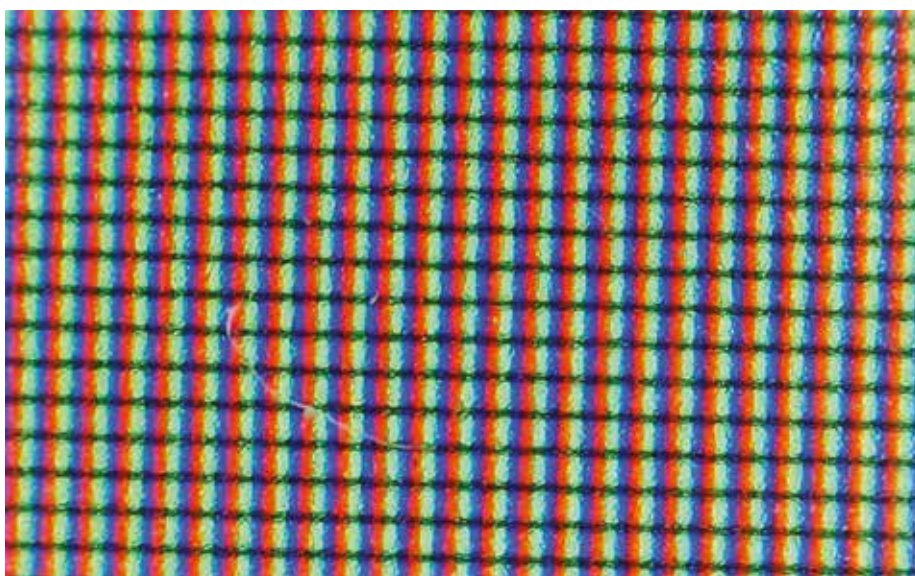

Image courtesy of Anand Singh and Tim Saunders



Fabric observed under the digital microscope



Pixels on the computer screen, as seen with the digital microscope

Images courtesy of Anand Singh and Tim Saunders

Figure 3: Supported by a clamp stand, the homemade microscope consists of a plastic tube with a lens (A) attached to one end and a webcam (B) to the other, attached to a computer. The sample (C) is clamped in place below the lens and a torch (D) is shone on it. The image can be zoomed by lengthening or shortening the tube (E).

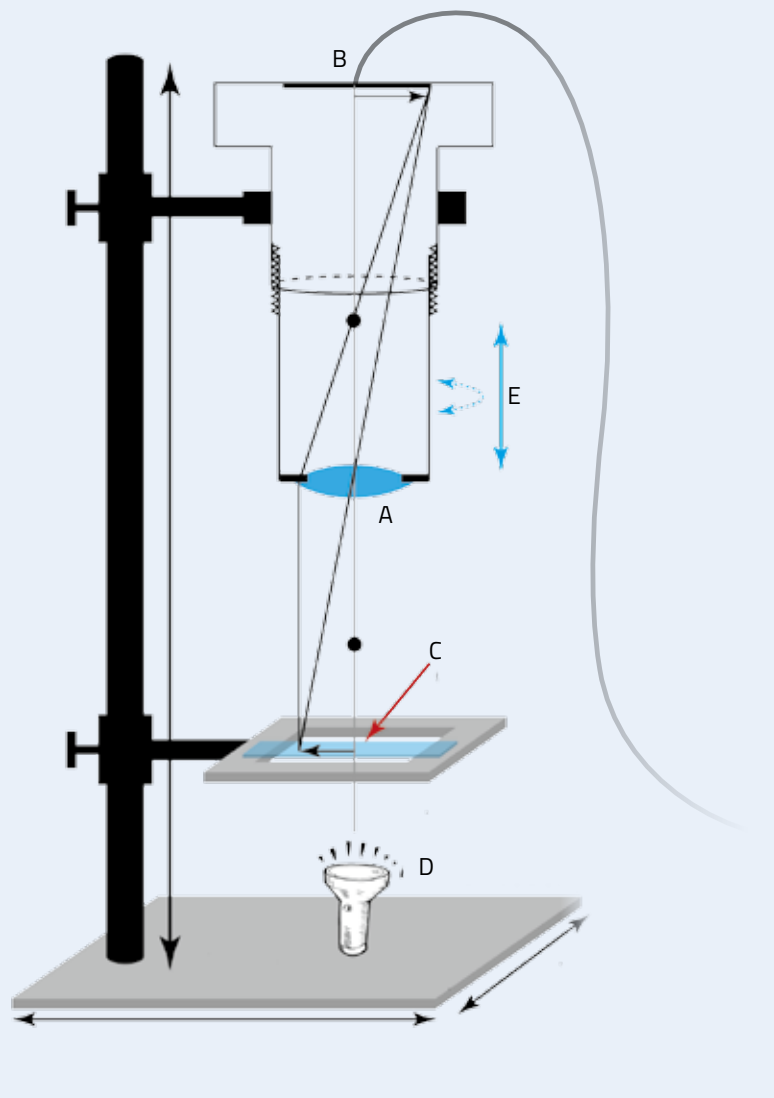

Image courtesy of Anand Singh and Tim Saunders

The microscope consists of a plastic tube with a lens attached to one end and a webcam to the other, attached to a computer. The microscope is supported by a clamp stand, the sample to be viewed is clamped in place below the lens, and a torch is shone onto or through the sample. The image is focused by the lens onto the image sensor of the webcam and thus passed to the computer for analysis. By adjusting the length of the tube or the relative positions of the microscope and sample, the image can be zoomed and focused. Figure 3 gives an overview of the construction, and full instructions

for building and adjusting the microscope can be downloaded from the *Science in School* website^{w1}.

The key difference between a digital microscope and a standard (analogue) school microscope is that students can take digital pictures that can be stored and analysed in later lessons. They can also easily make quantitative measurements using appropriate software. Furthermore, if resources are limited, the output from a single digital microscope can be projected onto a screen for the whole class to see. Finally, the digital microscope can be used to make videos, allowing a

unique view into the lives of plants and animals.

Constructing the microscope takes around one hour and can be done by students aged 14 years and over, perhaps in a small group. Allow another hour for using the microscope, an activity that is suitable for students of all ages.

Using your microscope

To start with, you could ask your students to examine the following samples under the microscope:

- Sugar, salt and sand grains
- Feather, hair, fabric or the torn edge of a piece of newspaper
- Mould on bread, fruit or vegetables
- Pond water to see microscopic organisms.

Using image software (e.g. the free software ImageJ^{w3}), they could then use quantitative measurements to make some forensic investigations, such as:

- Distinguishing hairs from different people based on their thickness
- Distinguishing hairs from different animal species based on colour, thickness or other characteristics
- Distinguishing sand or soil samples from different locations
- Distinguishing grains of sugar from grains of salt.

The digital microscope could also be used to quantify variability in microscopic samples. For example, your students could take 50 images of hair and measure the widths to find the mean and standard deviation of the hair width. Do they differ between hair colours? Between animal species? Such investigations are much more difficult to do with an analogue microscope.

By making movies with their digital microscope, your students could record the tracks of pond animals and compare the patterns of movement of different species. Over a longer period of time, they could even watch plants grow. For

Figure 4: Demonstrating Charles' gas law. When placed in hot water, the air in the bottle expands, filling the balloon.

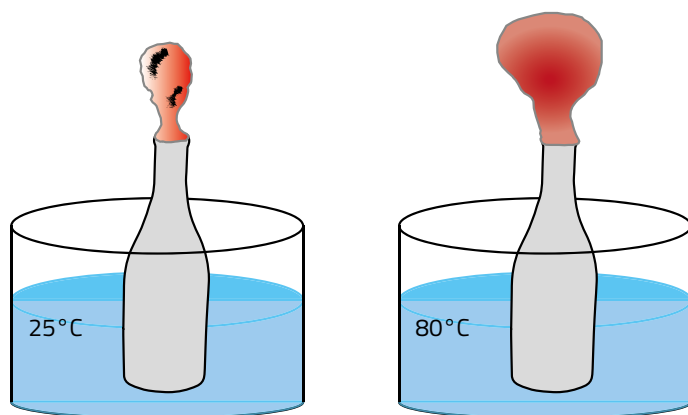

example, they could leave a plant root under the microscope for a week and get the computer to record an image every hour. Using the resulting movie, they could then plot a growth curve.

Gas laws

Demonstrating Charles' law

We all enjoy playing with balloons or watching hot-air balloons, but these activities are rarely related to the gas laws learned in the classroom. We therefore developed an experiment to show the relationship between the temperature and volume of a gas. This relationship is described by Charles' law, which states that, for a fixed amount of gas at constant pressure, the volume of the gas is directly proportional to its temperature.

This experiment takes around one hour and is suitable for students from around 14 years old. For older students, the activity can be adapted to experimentally estimate absolute zero.

Materials

- Balloons
- Hot (approximately 80°C) and room-temperature water
- Two dry and empty plastic bottles
- Two water tubs, large enough to fit the empty bottles

Procedure

1. Fill one of the water tubs with hot water and one with water at room temperature.
2. Place a balloon tightly over the mouth of each plastic bottle.
3. Submerge one bottle in the hot water and the other in the water at room temperature (figure 4).

Safety note: Care must be taken when using hot water.

This simple set-up maintains a fixed amount of gas (the contents of the bottle) at a fixed pressure (atmospheric). Once the bottle is placed in hot water, the temperature of the gas inside it increases and the gas expands – as described by Charles' law – and it begins to fill the balloon, as students will see (figure 4). Meanwhile, the volume of the balloon at the room temperature should remain the same.

This process is reversible. Remove the bottle from the hot water and place it in the water at room temperature: the balloon will slowly shrink again.

Another simple demonstration of Charles' law is to inflate a balloon, then place it in a freezer for about an hour and observe the change in volume. We also used balloons to demonstrate Boyle's law^{w1} – which states that at a constant temperature, the pressure of a fixed amount of gas changes inversely with its volume.

Estimating absolute zero

For older students (ages 16–19), absolute temperature can be roughly estimated by measuring the gas volume of a frictionless syringe at different temperatures.

Images courtesy of Anand Singh and Tim Saunders

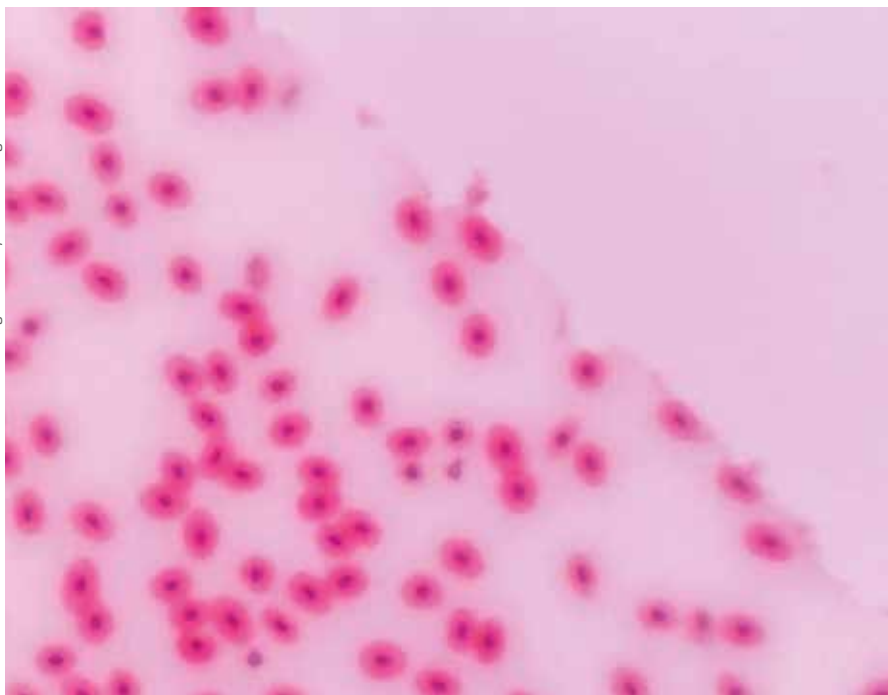

Frog blood cells observed under the digital microscope

Figure 5: From a plot of temperature ($^{\circ}\text{C}$) against gas volume (ml), absolute zero can be estimated by extrapolating to zero volume.

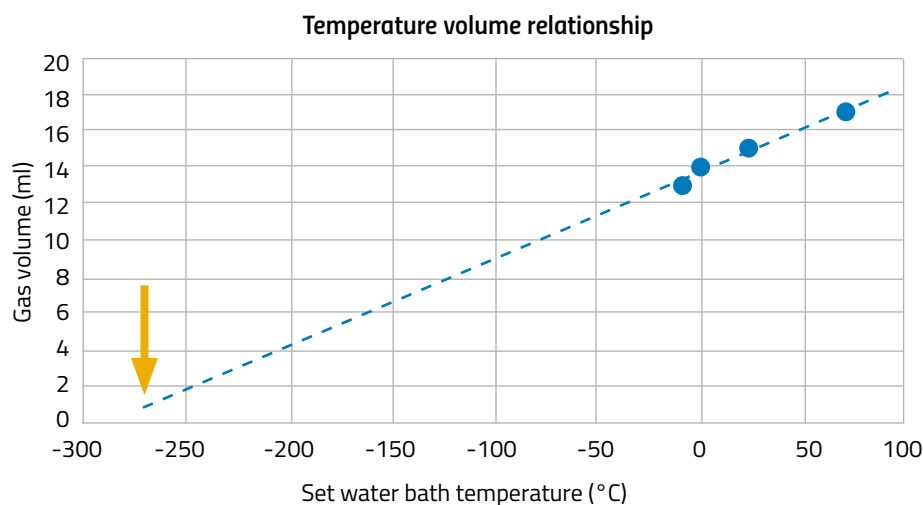

Image courtesy of Anand Singh and Tim Saunders

Materials

- Plastic syringe
- Oil or grease
- Modelling clay, glue or syringe caps to seal the syringe tip
- Waterbaths at 0, 10, 22 (room temperature), 50 and 80 $^{\circ}\text{C}$.

Procedure

1. Apply oil or grease to a plastic syringe to make it close to frictionless.
2. Draw a known volume of air into the syringe and seal the tip thoroughly.
3. Measure the air volume at different temperatures, e.g. using water baths at 0, 10, 22 (room temperature), 50 and 80 $^{\circ}\text{C}$.
4. Plot the temperature ($^{\circ}\text{C}$, x axis) against gas volume (ml, y axis). You should find a linear relationship between temperature and volume. By extrapolating to zero volume, the corresponding temperature on the x axis can be seen to be approximately 270 $^{\circ}\text{C}$ (the actual value of absolute zero is -273.15°C).

Web references

- w1 Further information about these and other activities used in the workshops can be downloaded from the *Science in*

School website. See: www.scienceinschool.org/2015/issue34/india

- w2 To learn more about the reflective properties of light, see *Mirror, Mirror on the Wall: Angles of Reflection*. See www.optics4kids.org or use the direct link: <http://tinyurl.com/mirrorwall>
- w3 The imaging software ImageJ can be downloaded free of charge from the website of the US National Institutes of Health. See: <http://imagej.nih.gov/ij>
- w4 Watch a video showing the experiment to calculate absolute zero using a fixed volume of gas at different temperatures. See: <https://www.youtube.com/watch?v=wkWo-8tY8cY>

Resources

For visual demonstrations of how lenses, mirrors and other optical components change the light path, see:

A plane mirror reflection experiment. See www.education.com or use the direct link: <http://tinyurl.com/o2mf8mc>

A video on light experiments using a fish tank: <https://www.youtube.com/watch?v=aN1saYRr6z4>

An experiment to deflect a laser beam on the EU Hands-on Universe website. See: <http://www.pl.euhou.net/docupload/files/Excercises/WorldAroundUs/Refraction/refraction.pdf> or use the direct link: <http://tinyurl.com/qx3gffu>

To learn about early microscopes and how to build a compound microscope using cheap materials, see:

Tsagliotis N (2012) Build your own microscope: following in Robert Hooke's footsteps. *Science in School* **22**: 29-35. www.scienceinschool.org/2012/issue22/microscope

Instructions and supporting material for building and using Galileo's microscope on the website of the Museo Galileo. See: <http://www.museogalileo.it> or use the direct link: <http://tinyurl.com/q244pfr>

Instructions for building a 'one-dollar microscope' on the Funsci website. See www.funsci.com or use the direct link: <http://tinyurl.com/9wvvgp>

For other microscopy resources, see:

Microworlds, an exploration of the microscopic world on the Funsci website. See www.funsci.com or use the direct link: <http://tinyurl.com/oxnrh68>

A paper microscope: Cybulski JS, Clements J, Prakash M (2014) Foldscope: origami-based paper microscope. *Plos One* **9**(6): e98781. doi: 10.1371/journal.pone.0098781
Plos One is an open-access journal, so all articles are freely available online.

A microscope on a mobile phone: Smith ZJ et al. (2011) Cell-phone-based platform for biomedical device development and education applications. *PLoS ONE*, 2011. **6**(3): p. e17150. doi: 10.1371/journal.pone.0017150

Plos One is an open-access journal, so all articles are freely available online.

Instructions for preparing slides of garlic or onion cells on the Funsci website. See www.funsci.com or use the direct link: <http://tinyurl.com/pajppg6>

For instructions for experiments on Charles' law, see the common gas law demonstrations on the website of North Carolina State University. See <http://ncsu.edu> or use the direct link: <http://tinyurl.com/pq7qu6h>

For video experiments with balloons on water and air compressibility, see: <https://www.youtube.com/watch?v=jjToLlG7GAI>

For background information relevant to the development of our workshops, see:
Denofrio LA et al (2007) Linking student interests to science curricula. *Science* **318**: 1872-1873. doi: 10.1126/science.1150788
Donald B (2013) Stanford scholars find varying quality of science and tech education in Brazil, Russia, India and China. *Stanford Report*: 19 August. <http://news.stanford.edu> or use the direct link: <http://tinyurl.com/pbmrnvu>
Leshner AI (2007) Outreach training needed. *Science*: **315**: 161. doi: 10.1126/science.1138712

References

Saunders T (2011) The physics of crowds. *Science in School* **21**: 23-27. www.scienceinschool.org/2011/issue21/crowding

Essex J, Howes L (2014) Experiments in integrity – Fritz Haber and the ethics of chemistry. *Science in School* **29**: 5–8. www.scienceinschool.org/2014/issue29/ethical_chemistry

Anand Singh is a post-doctoral fellow at the Mechanobiology Institute, National University of Singapore, Singapore (MBI). He loves building new microscopes, and he uses these to study biological processes ranging in scale from the sub-cellular to whole embryos. He enjoys outreach and has been involved in developing simple tools for science workshops and public outreach.

Anuradha Gupta is a post-doctoral fellow at the Inter-University Centre for Astronomy and Astrophysics, Pune, India. She is an astrophysicist and promotes basic education for underprivileged children, especially for girls in India.

Ranjit Gulvady is a fourth-year graduate student at MBI. He is a single-molecule biophysicist who uses light microscopy to understand physical properties of biological molecules like DNA. During high school, he organised several science demonstrations for school children and later in college he helped children from especially underprivileged backgrounds to understand basic science and mathematics.

Amit Mhamane did his bachelor's and master's degrees in biotechnology at the University of Mumbai, India, and now is doing a PhD in chemistry at the Max Planck Institute of Molecular Physiology, Dortmund, Germany.

Timothy Saunders is a group leader at MBI. His group works on understanding how embryos reliably develop from a single fertilised cell to a complex organism. He has taught biology to adult learners who had previously failed their school science exams (one lesson was published in *Science in School*, see Saunders, 2011) and he is currently involved with the Science outreach and education committee at MBI.



About *Science in School*

Science in School is the only teaching journal to cover all sciences and target the whole of Europe and beyond. The free quarterly journal is printed in English and distributed across Europe. The website is also freely available, offering articles in 30+ languages.

Science in School is published and funded by EIROforum (www.eiroforum.org), a partnership between eight of Europe's largest inter-governmental scientific research organisations.

With very few exceptions, articles in *Science in School* are published under Creative Commons licences, so that you can

copy and republish the text non-commercially. See www.scienceinschool.org/copyrightViews and opinions expressed by authors and advertisers are not necessarily those of the editors or publisher.

Advertising: tailored to your needs

For details of how to advertise on the *Science in School* website or in the print journal, see www.scienceinschool.org/advertising or contact advertising@scienceinschool.org

Imprint

Science in School
European Molecular Biology Laboratory
Meyerhofstrasse 1
69117 Heidelberg
Germany
editor@scienceinschool.org
www.scienceinschool.org

Publisher: EIROforum, www.eiroforum.org

Editor-in-chief: Dr Eleanor Hayes

Editors: Isabelle Kling and Laura Howes

Editorial board:

Dr Giovanna Cicognani, Institut Laue-Langevin, France
Dr Dominique Cornuéjols, European Synchrotron Radiation Facility, France
Richard Hook, European Southern Observatory (ESO), Germany
Dr Rolf Landua, European Organization for Nuclear Research (CERN), Switzerland

Dr Dean Madden, National Centre for Biotechnology Education, University of Reading, UK

Dr Petra Nieckchen, EUROfusion, UK

Joseph Piergrossi, European XFEL, Germany

Dr Silke Schumacher, European Molecular Biology Laboratory, Germany

Monica Talevi, European Space Agency, the Netherlands

Dr Fernand Wagner, European Association for Astronomy Education, Luxembourg

Copy editor: Dr Caroline Hadley, Inlexio, Australia

Composition: Graphic Design Studio Nicola Graf, Germany

Design: Manuela Beck, European Molecular Biology Laboratory, Germany

Printer: Colordruck Leimen, Germany

Distributor: CFG Circle Fulfillment GmbH, Germany

Web development: Alperion GmbH & Co KG, Germany

ISSN

Print version: 1818-0353

Online version: 1818-0361

How many schools and teachers do you reach worldwide?



Advertising in *Science in School*

- Choose between advertising in the quarterly print journal or on the website.
- Website: reach over 50 000 global science educators per month.
- In print: target over 5000 European science educators every quarter.
- Distribute your flyers, brochures or other materials to to our subscribers.

For more details, see www.scienceinschool.org/advertising



Published and
funded by EIROforum



EUROfusion

EMBL



esa

